

making strong connections

Machining

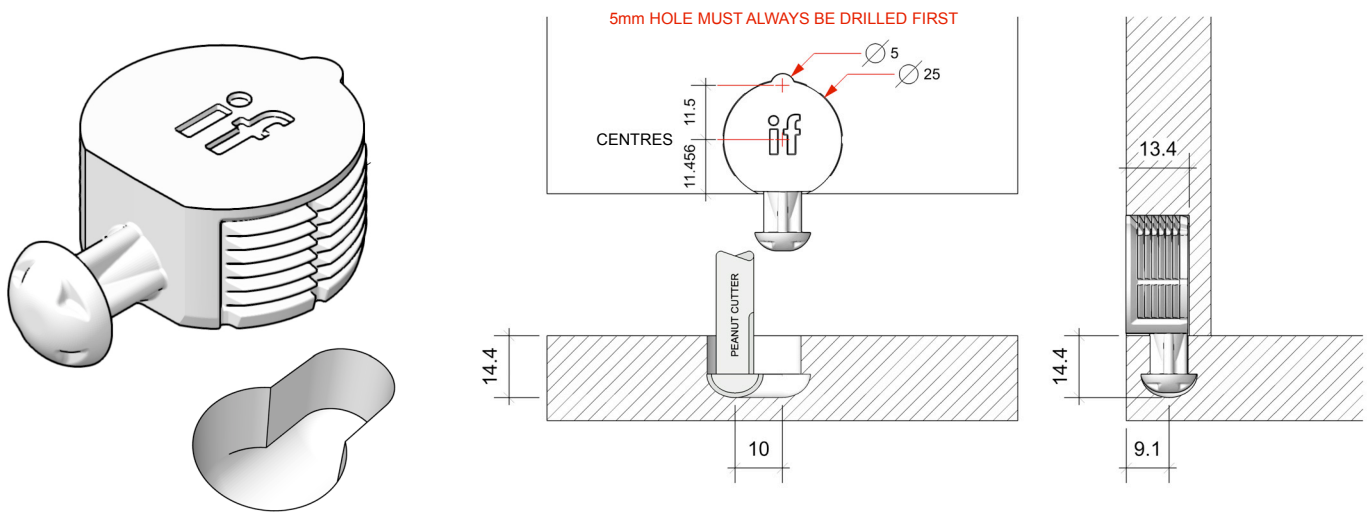

Assembly

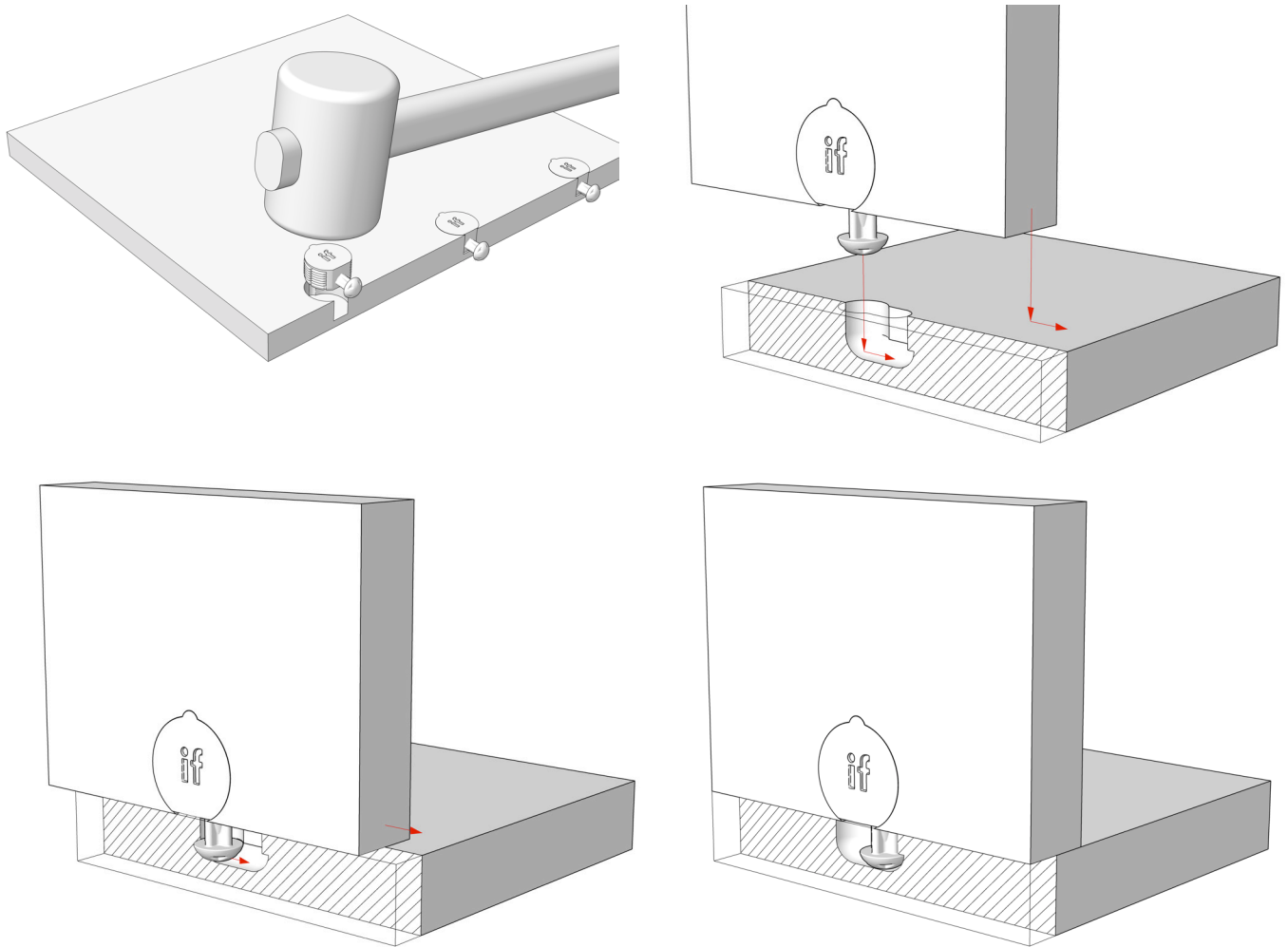

Visit our website for more useful information, news, videos and lots more....

making strong connections

Applications

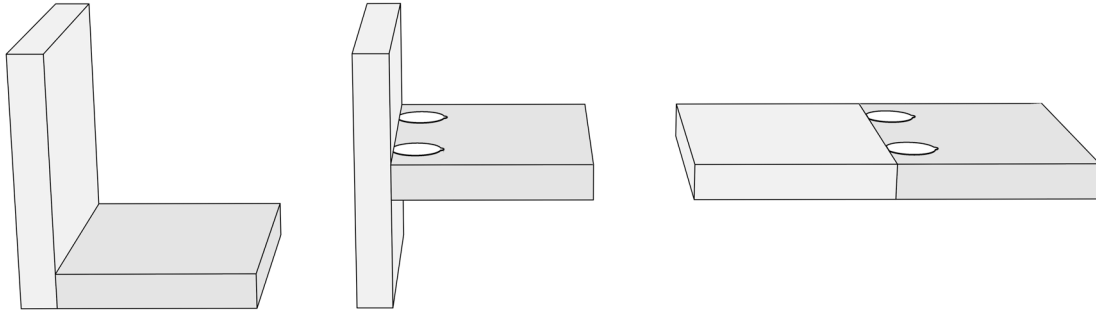

Technical Specification

PEANUT® 1 Technical data

COMPONENT COMPOSITION	GLASS-FIBRE REINFORCED PLASTIC
MATERIAL THICKNESS	>15.3mm
TOLERANCE (25mm HOLE)	+ 0.1mm - 0.25 (DIAMETER)
TOLERANCE (PEANUT CUTTER SLOT)	+ 0.7mm - 0.3mm (DEPTH)

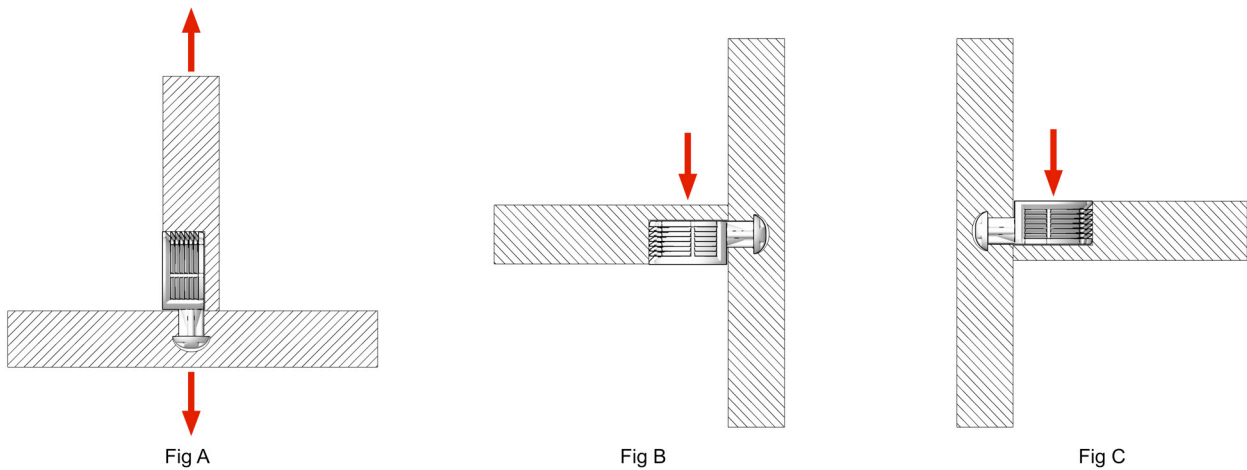

PEANUT® 1 Tensile/shear strength (based on 2 components)

MATERIAL	TENSILE STRENGTH (Fig A)		SHEAR STRENGTH (Fig B)		SHEAR STRENGTH (Fig C)	
PARTICLE BOARD (18mm MFC)	1350N	135KG	1200N	120KG	650N	65KG
MDF (18mm)	3000N	300KG	1350N	135KG	950N	95KG

All testing has been carried out in-house (independent testing will be carried out early in 2019)

PEANUT® 1 Tooling requirements (please note: 5mm hole must always be drilled first)

IF SOLID CARBIDE PEANUT CUTTER	MAX RPM 14000	CREATES 6500+ SLOTS (BASED ON MELAMINE FACED PARTICLE BOARD) THIS TOOL CANNOT BE SHARPENED
5mm SOLID CARBIDE DRILL		ANY 5mm DRILL WILL WORK (WE HAVE FOUND THE SOLID CARBIDE DRILL WE SUPPLY GIVES BEST RESULTS)
25mm HIGH PERFORMANCE DRILL		ANY SUITABLE 25mm DRILL WILL WORK (WE HAVE FOUND THE CUTTER WE SUPPLY GIVES BEST RESULTS)

A standard PVA wood glue can be used for added strength and a permanent joint.

PEANUT® 1 Is available in these colours

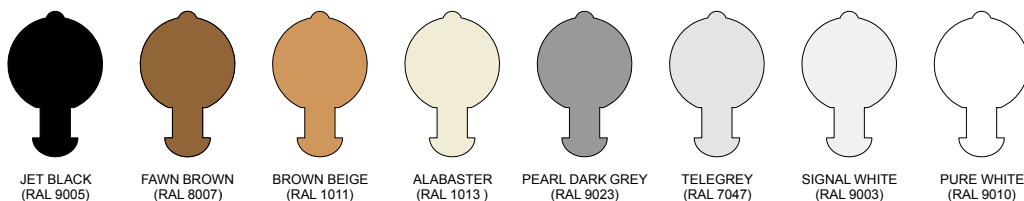

PRINTED COLOURS ARE INTENDED AS A GUIDE ONLY, ACTUAL COLOUR OF PRODUCT MAY VARY