

Mounting instructions

MEGANT® 1060x150x50

Visible installation

Regular size overview

ALU AW 6005

Connector plate specs

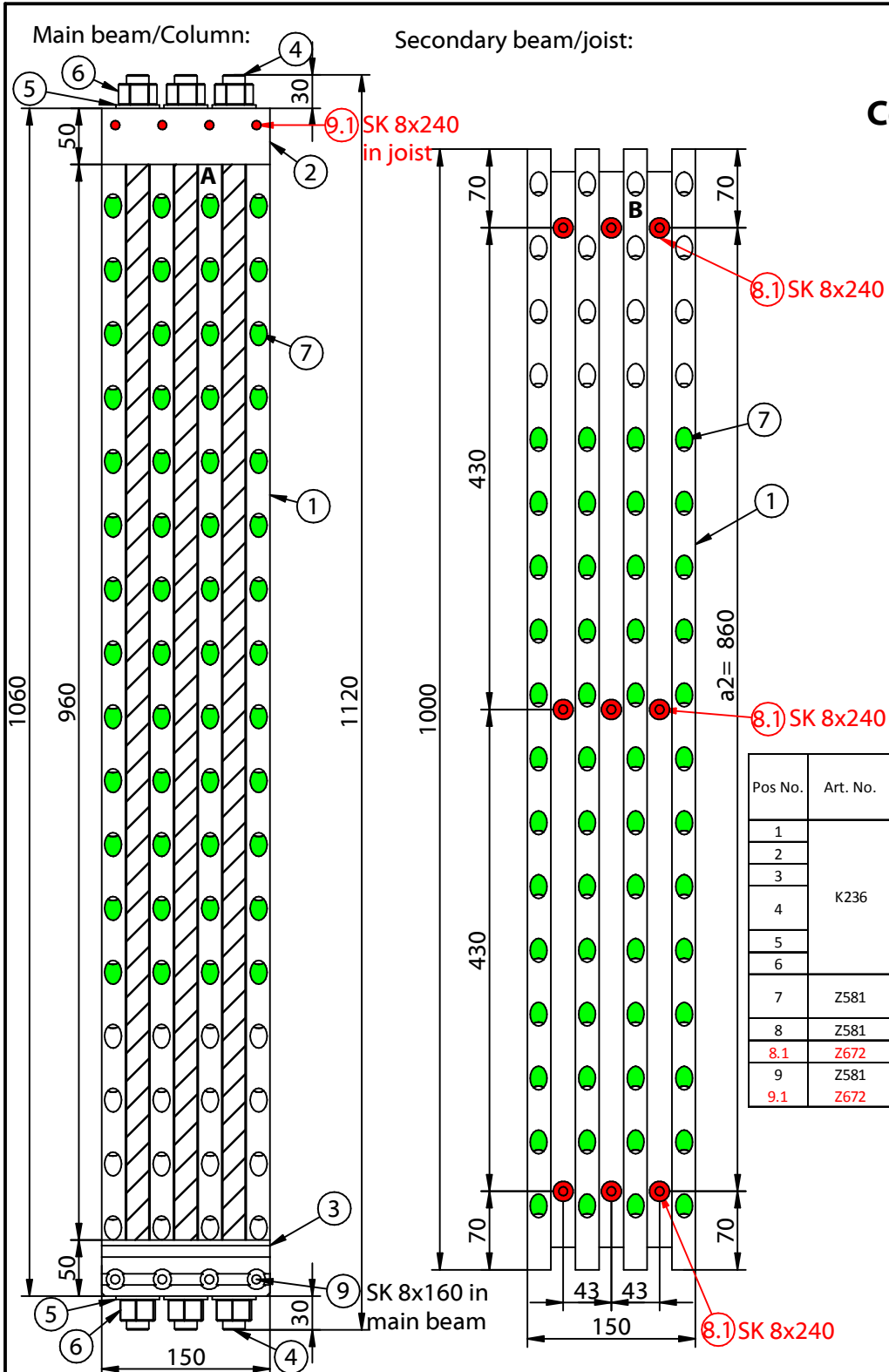
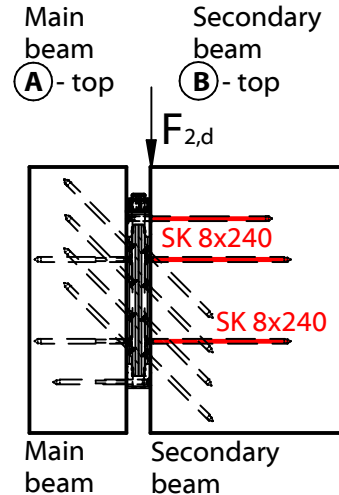

Pos No.	Art. No.	part description	MEGANT (AW 6005)	
			1060x150	Art. No. K236
1	K236	connector plates	1000x150x25	
2		clamping jaws top	50x50x150; D20	
3		clamping jaws bottom	50x50x150; M20	
4		threaded rod	3xM20x1120 (Z924/1120)	
5		washer	6xM20	
6		nut	6xM20	
7	Z581	inclined screws	104x SK8x160	
8	Z581	horizontal screws	9x SK8x160	
8.1	Z672	horizontal screws	9x SK8x240	
9	Z581	screws clamping jaw	4x SK8x160	
9.1	Z672	screws clamping jaw	4x SK 8x240	

MEGANT 1060x150x50
(Art.No. K236)

This drawing is the exclusive property of KNAPP GmbH

© Knapp GmbH. All measures in mm - Errors excepted. VERSION 01 04.09.2018

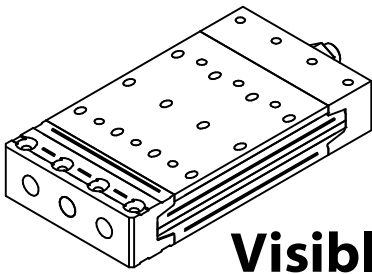

Mounting instructions

MEGANT® 1120x150 x50

Visible installation

Regular size overview

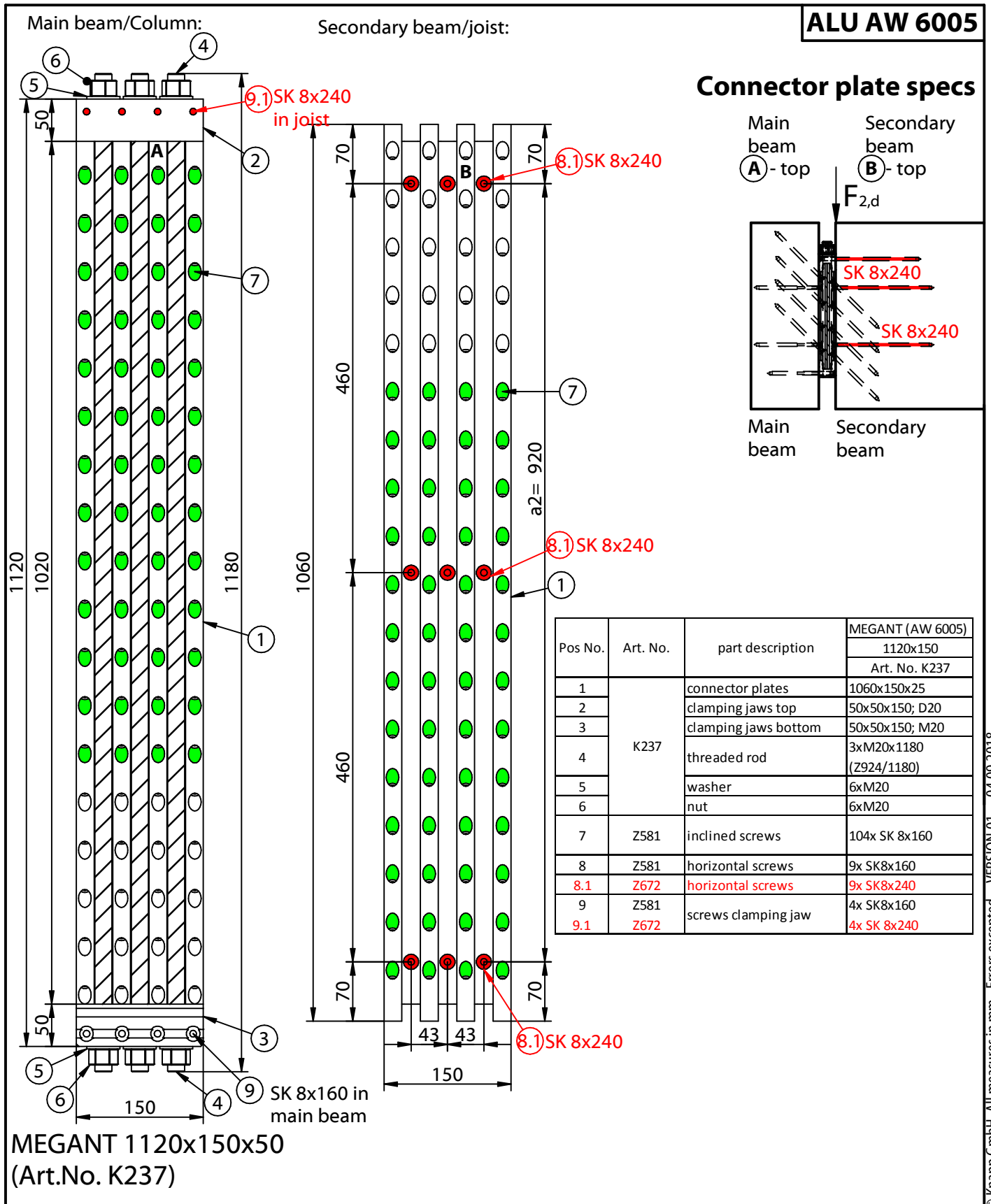

Mounting instructions

MEGANT® 150

Hole pattern for visible central installation

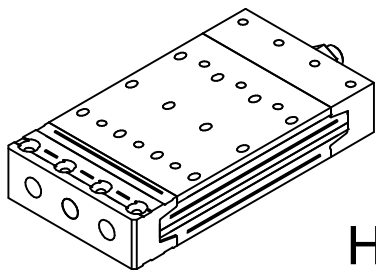

ALU AW 6005

Pre-drill layout in main beam !

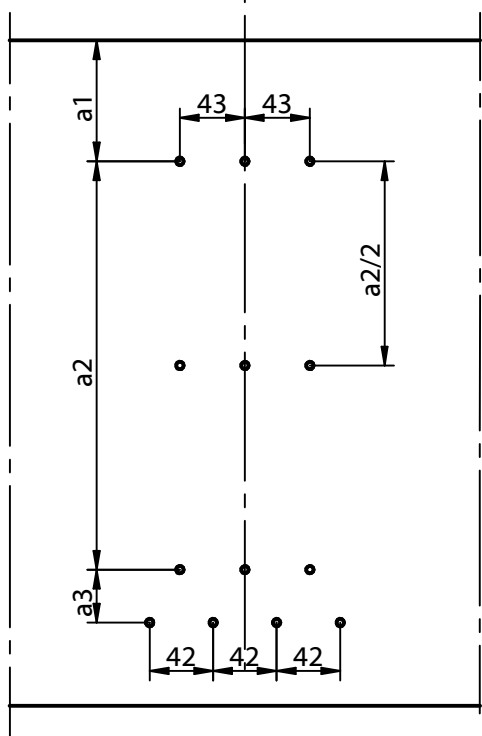

Softwood:
13x drillings
Ø 5mm,
depth 30 mm

Hardwood:
13x drillings
Ø 6mm,
depth screw-
length ~120 mm

Pre-drilling visible installation of connector

Secondary beam	Pre-drill spacings a1 with respect to secondary beam member height H_N	
Height H_N [mm]	MEGANT® 1060x150	MEGANT® 1120x150
1200	170	
1240	190	
1280	210	180
1320	230	200
1360	250	220
1400	270	240
1440	290	260
1480	310	280
1520	330	300
1560	350	320
1600	370	340
1640	390	360
1680	410	380
1720	430	400
1760	450	420
1800	470	440
1840	490	460
1880	510	480
1920	530	500
1960	550	520
2000	570	540

Drilling positions for centered mounting in secondary beam !

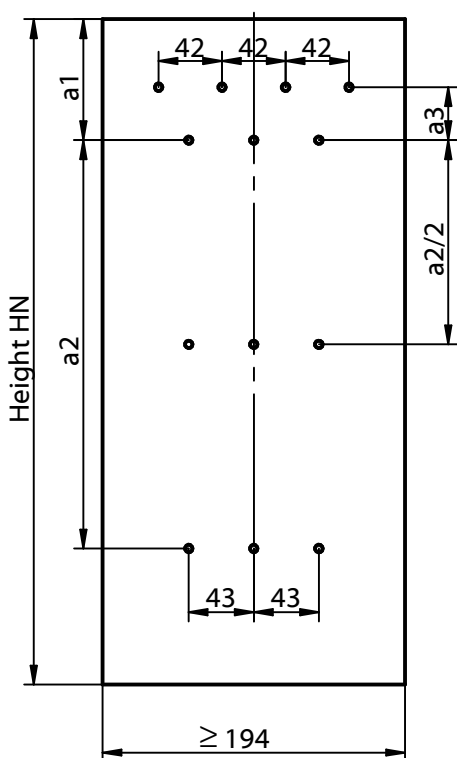

Softwood:
13x drillings
Ø 5mm,
depth 30 mm

Hardwood:
13x drillings
Ø 6mm,
depth screw-
length ~120 mm

Distance	MEGANT® 1060x150	MEGANT® 1120x150
a2 [mm]	860	920
a3 [mm]	85	85

MEGANT marking templates for horizontal drilling are available in different sizes upon request.

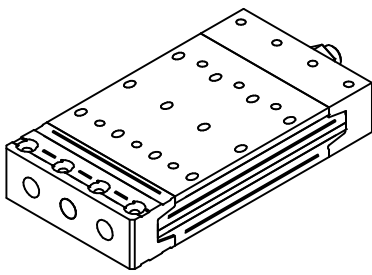

Mounting instructions

MEGANT® 150

Install MEGANT **visibly** on main beam

ALU AW 6005

1.)

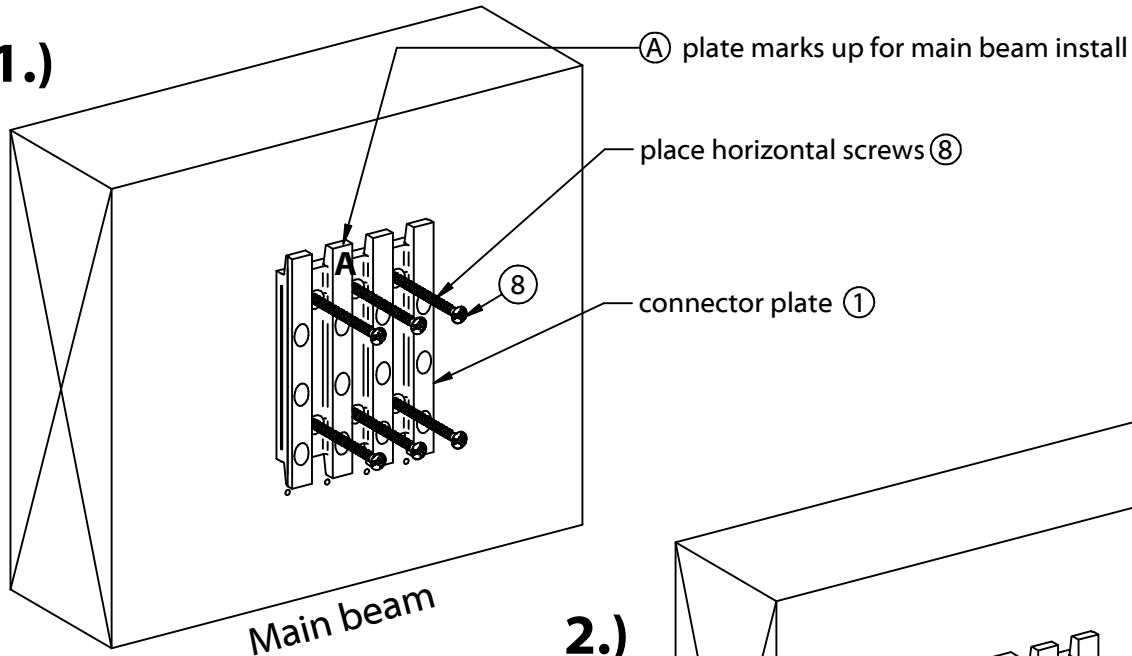

Ⓐ plate marks up for main beam install

place horizontal screws ⑧

connector plate ①

Main beam

2.)

Inclined screws ⑦ in connector plate ②.
Start screwing from top down.
Use max. 20Nm torque setting.
Mount connector plate firmly

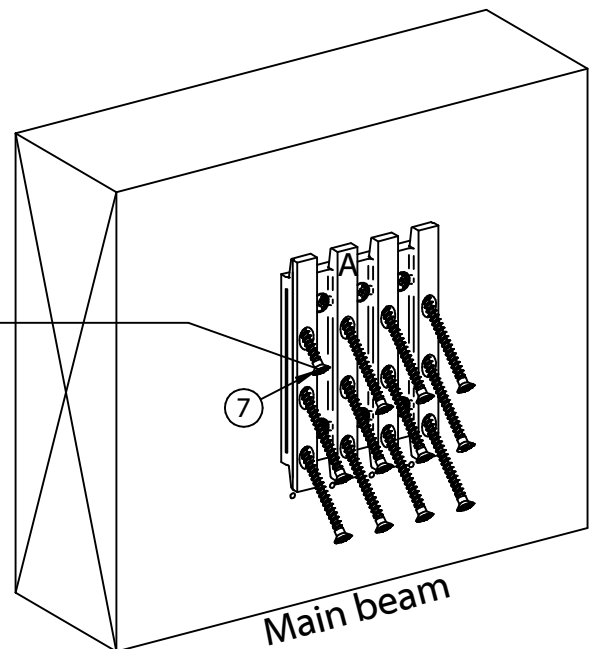

⑦

Main beam

3.)

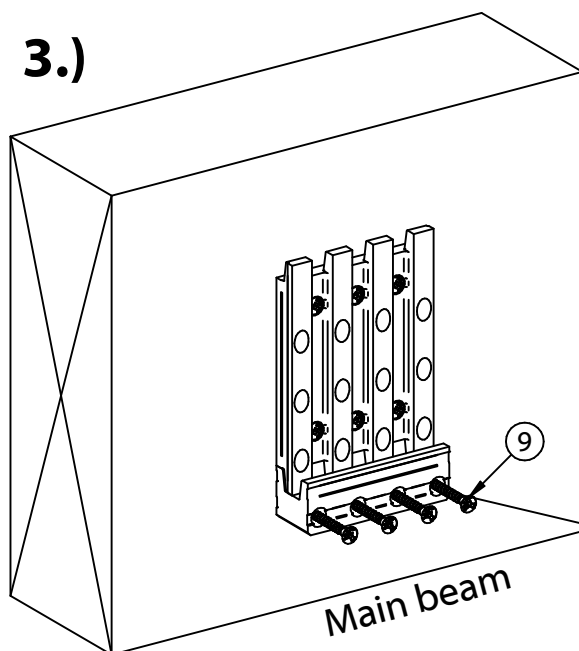

For **hardwood** main beam
SK 8x120 screws are usually used.

Clamping jaws ② mounted at bottom.
Use clamping jaw screws ⑨ for installation

Main beam

Mounting instructions

MEGANT® 150

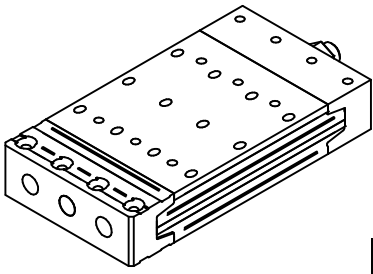

Install MEGANT **visibly** on secondary beam

ALU AW 6005

1.)

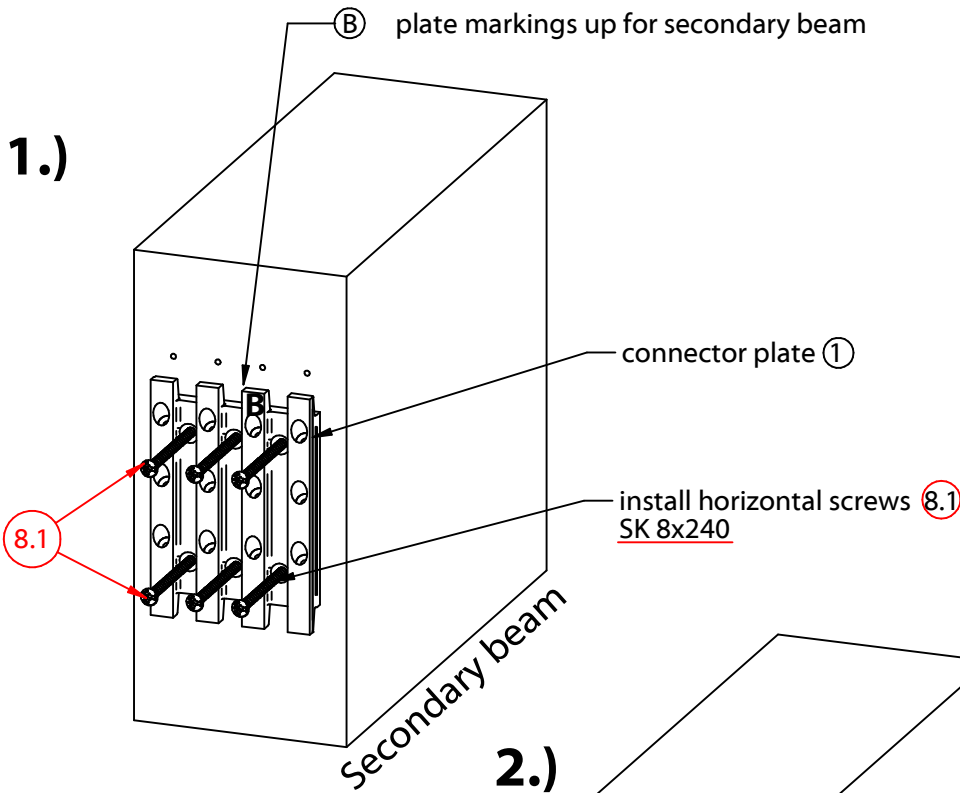

2.)

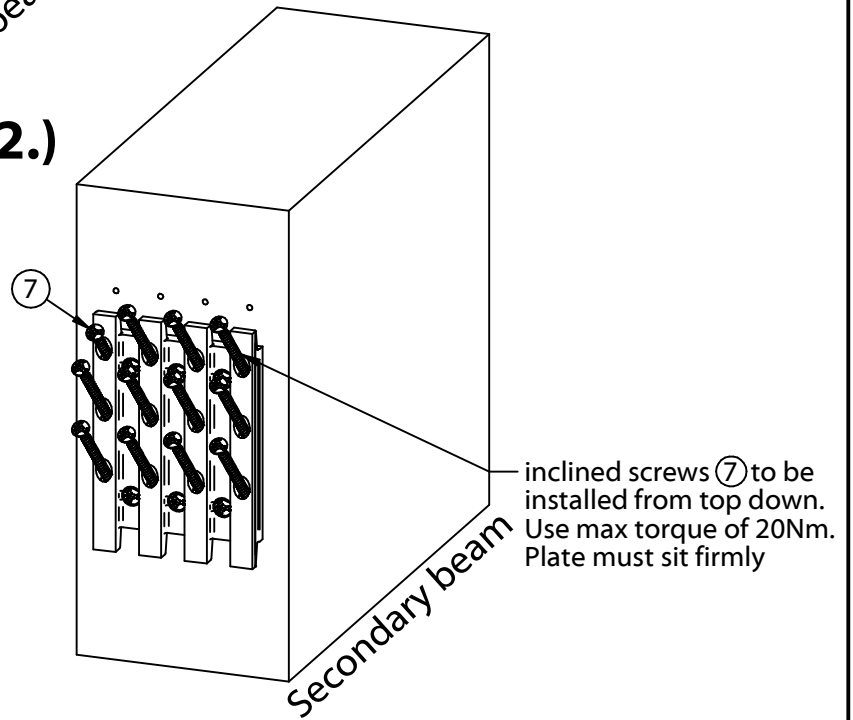

3.)

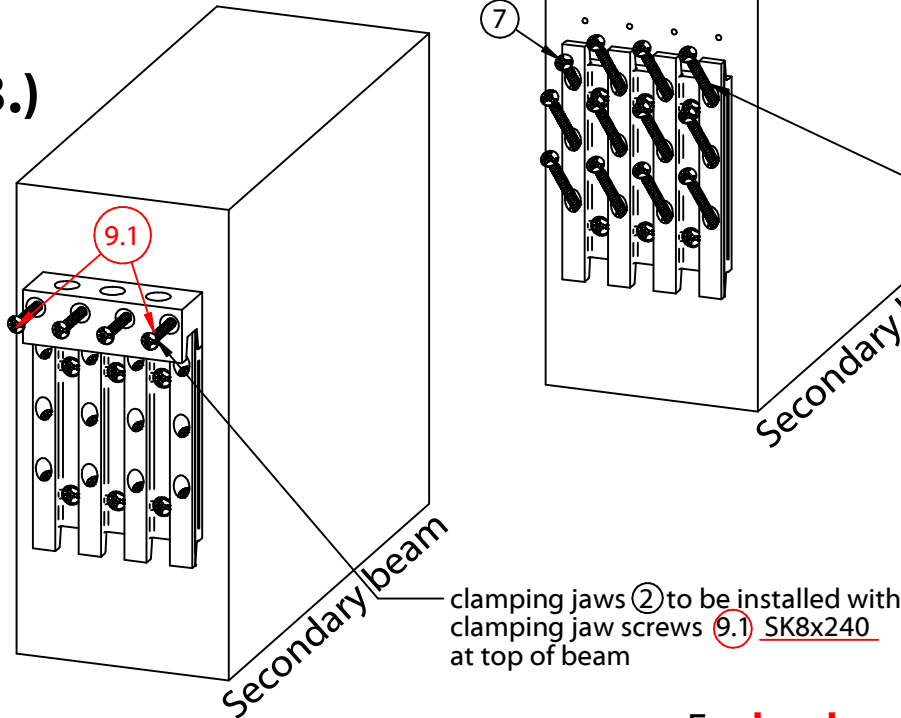

For **hardwood** secondary beam **SK 8x120** screws are usually used.

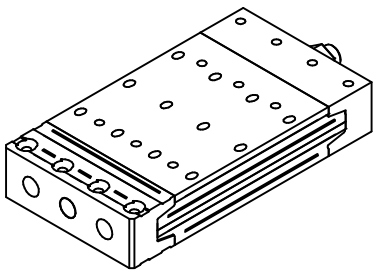

Mounting instructions

MEGANT® 150

Visible installation

ALU AW 6005

1. Install secondary beam

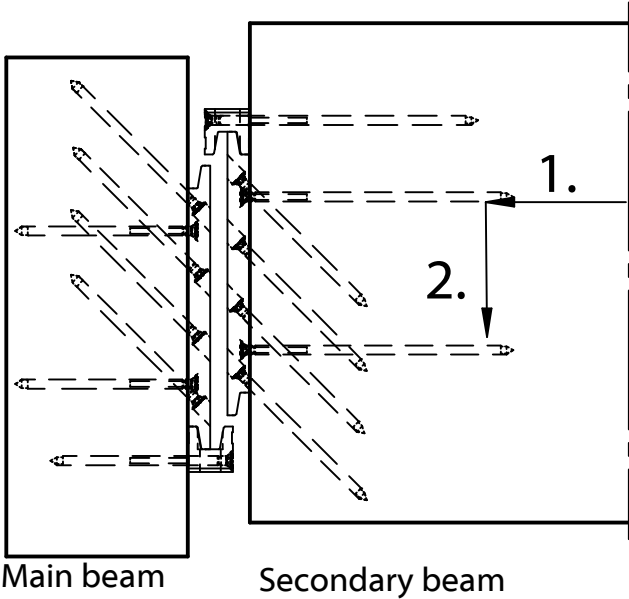

2. Install M20 threaded rod (4) in lower clamping jaw (3) with 30 mm overlap

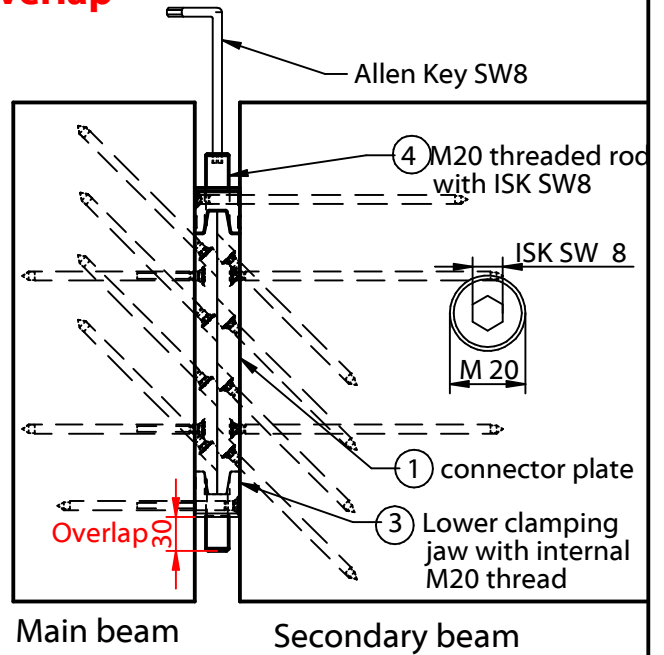

3. Place washer and nut M20 on the top and bottom

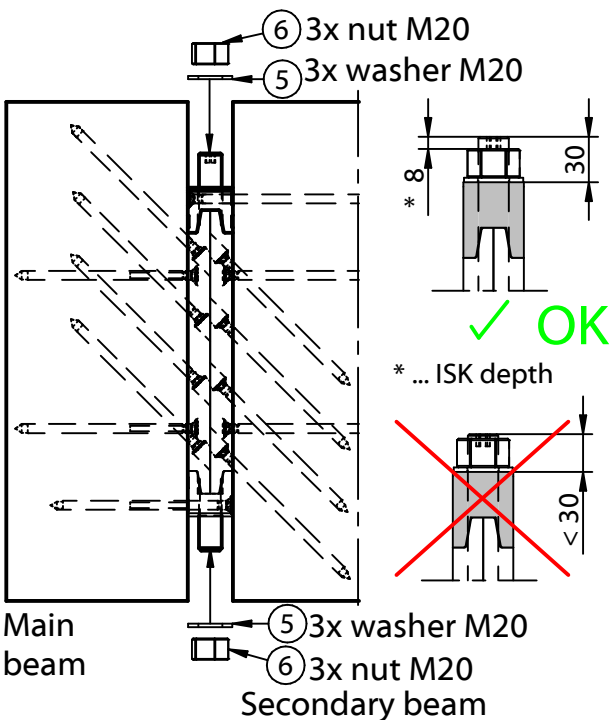

4. Tighten M20 nut on the top and bottom with SW 30 wrench (40 Nm) !

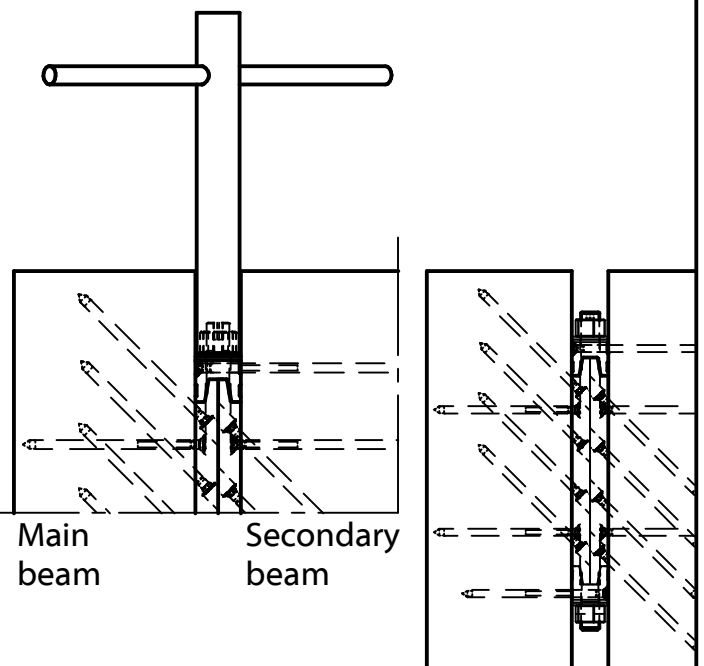

This drawing is the exclusive property of KNAPP GmbH

© Knapp GmbH. All measures in mm - Errors excepted. VERSION 01 04.09.2018