

Connecting systems

for modern timber construction

Certainly a great connection.



CE ETA

NEW | Additionally with hardwood material

KNAPP[®]
connectors.com

Welcome to the World of KNAPP®!

As a producer of patented connecting systems we develop and produce high-quality products which are distributed worldwide. Not only will our connecting systems convince – but also inspire you with the wide range of applications. The comprehensive service offers you the possibility to find the best, the most efficient and innovative solution for the realisation of your products. On the following pages you will find our connector systems for modern timber construction. Every connector permits high prefabrication and possesses the CE-Marking through European certification of standards. Regular external inspection guarantees maximum security for planners, architects, manufacturers and owners.



Friedrich Knapp
Company Founder

Our Service

The KNAPP®-Team provides competent advice and excellent service for your projects.

In Germany and Austria we offer full-coverage service by representatives on-site. You will find the right contact person easily and quickly.

www.knapp-connectors.com/ad

You can reach our internal consultants in Germany and Austria, Monday – Tuesday 8 a.m. to 5 p.m. and on Friday 8 a.m. to 13 p.m.

You can reach our global sales manager on phone +43 (0)664 / 88 51 52 87 or E-Mail : globalsales@knapp-connectors.com

www.knapp-connectors.com/contact

Our Planner Service



Planner service



You can visit our online-shop 24 hours a day. Here you will receive comprehensive information about products and service. After one-time registration you will be able to use the download area.

www.knapp-connectors.com/download

We offer comprehensive planning and structural-engineering calculations for architects, planners and structural engineers. Contact us for your next project! We'd like to offer you statics pre-dimensioning, recommending the right connector from KNAPP®. Benefit from our know-how, many years of experience and rely on our engineers consulting.

www.knapp-connectors.com/planner

KNAPP® online-store | Order around the clock



24h bestellen
online-store



You want to be flexible and order at any time? No problem! In our online-store you can easily find the most fitting connecting system for any purpose and send your order by one mouse click. After a quick registration, you can immediately start buying online.

www.knapp-connectors.com/online-store

KNAPP® offers the right connection for the areas of:

- Timber construction
- Post-beam wood-glass-facade
- Prefab walls
- Timber construction engineering
- Door- and window construction
- Furniture and interior design
- Glued glass elements for timber and metal construction



More information

www.knapp-connectors.com/folder



RICON® | The connector for main and secondary beam up to 26 kN*

System advantages:

- | Applications for concealed main – secondary beam connections
- | Slim profile – timber width from 50 mm upwards
- | Universal access to all wood materials, steel or concrete
- | High degree of prefabrication – fast and exact mounting on-site
- | Elements are joint together without screwing
- | Adjustment of distance between joints and building tolerances
- | Fire resistance (DIN 4102-2) by 4-sided concealed mounting
- | Application admissible also with interlayer
- | Dismounting and remounting possible for several times
- | Increased resistance to corrosion for indoor swimming pools, riding halls, stables and agricultural buildings
- | **NEW:** ETA additionally with hardwood material

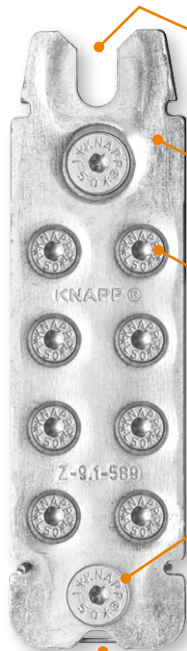

The dove-tail stamping makes it very easy to catch the CS-screws and push together the connector. It also ensures tightness.

RICON® consists of two identical parts. It is made of premium quality steel and is hot-dip galvanized and made in Austria.

Ø = 5 mm and Ø = 8 mm RICON® CS-screws. These adjustable holding screws compensate fabrication tolerances. The reinforced shaft with integrated stop guarantees exact positioning.

Clip in the stainless spring steel stirrup into the locating slots prior to final assembly. It locks the connection against the slide-in direction and can be released again.

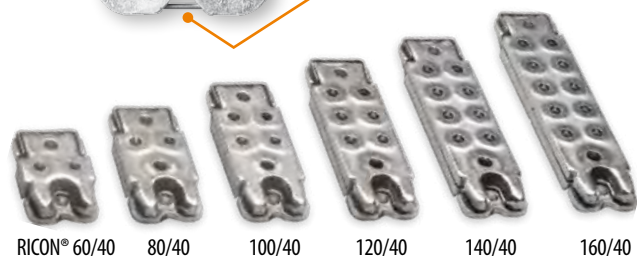

Resistance to corrosion:
RICON® for indoor swimming pools. Special coating on request (for example near coastal areas).



Resistance to corrosion:
RICON® for riding halls, stables and agricultural buildings.

More information:
www.knapp-connectors.com/ricon

*Charact. load carrying capacity $F_{z,Rk}$ in insertion direction applies only to the use of original KNAPP® cs-screws according to ETA 10/0189.

RICON®

Application examples and connection details

Main / secondary beam connections
e.g. beamed ceilings, roofs and sun rooms.

Connection to steel

Connecting concrete wall
e.g. with RICON® 140/40

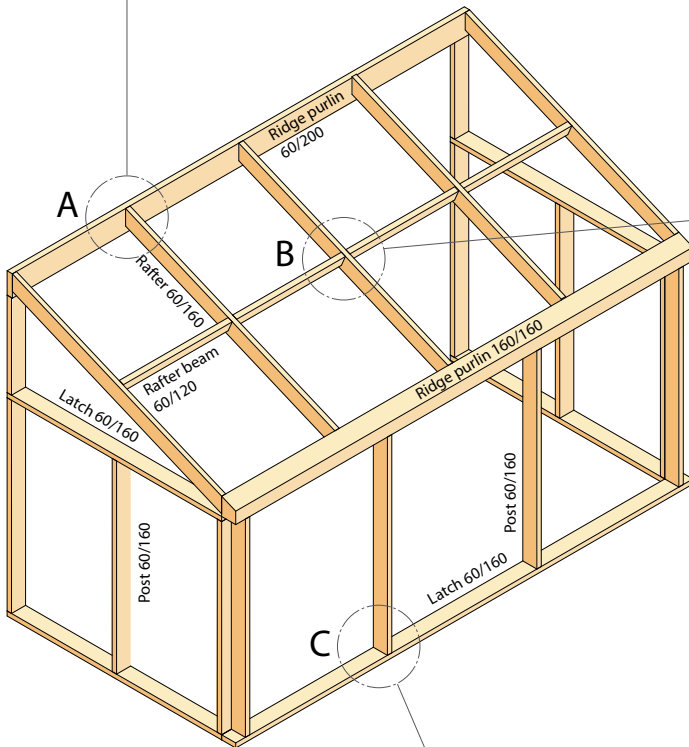
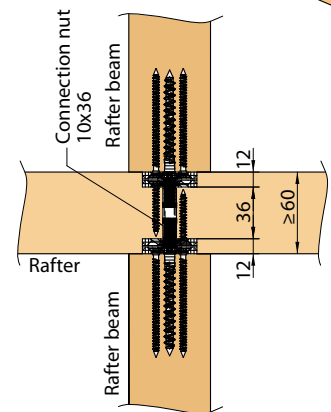
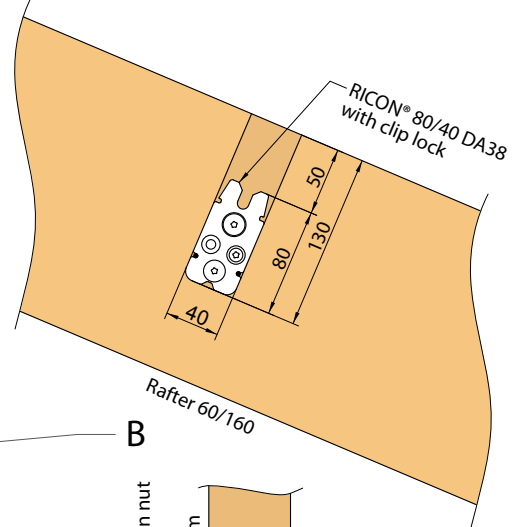
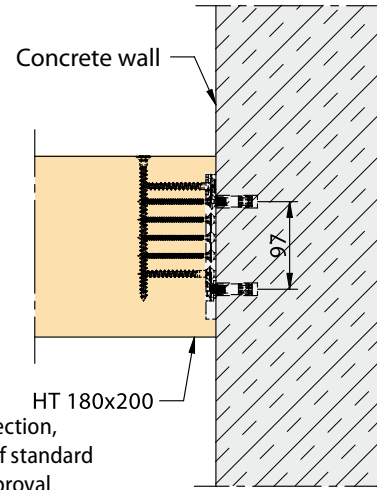
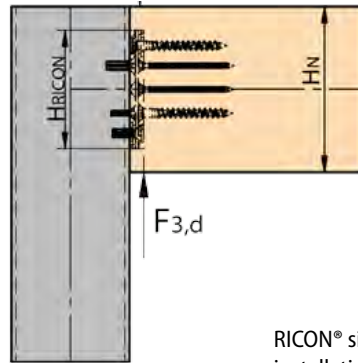
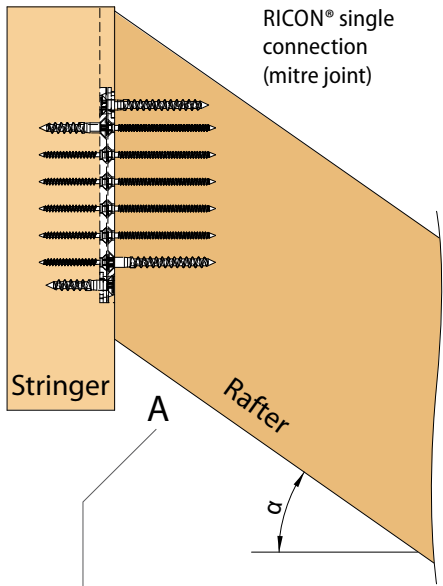

RICON® single connection

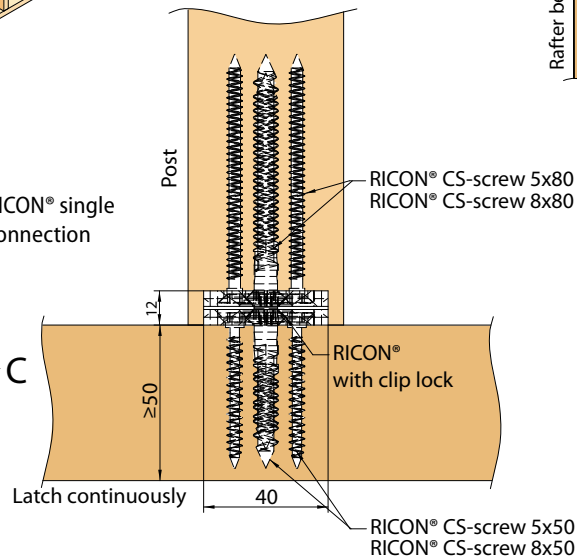

Installation example:
Construction of a sun room.

(All dimensions in mm)

RICON® 60/40

Characteristic values for dimensioning can be taken from the ETA Static Folder.

Minimum timber cross section

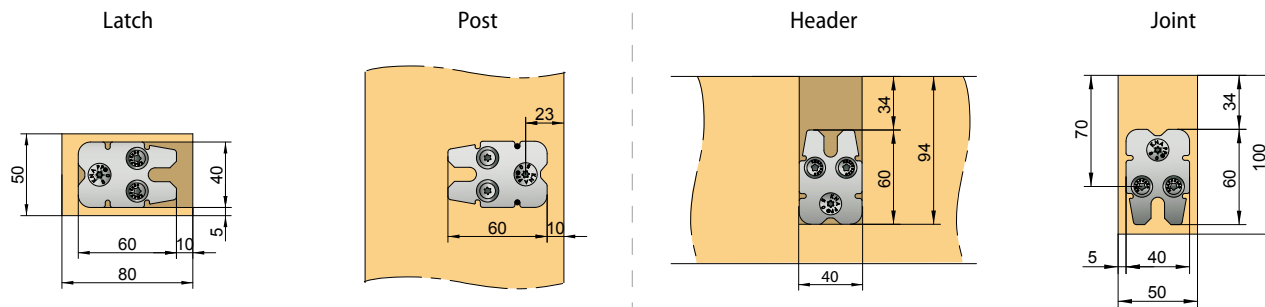

Minimum timber width: 50 mm

Minimum timber width: 60 mm

Single connection (EA) with RICON® CS-screws

Art.-No. K360

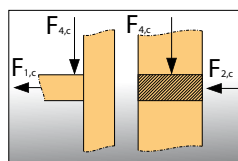

Single connection for post and latch connection with a minimum timber cross section of 50 mm (stress at mid to the axis of latch)

Connector	Connection	Screwing		Charact. values [GL24h]	
		Joint	Header	$F_{1,Rk}$ [kN]	$F_{2,Rk}$ [kN]
60/40	EA	2 x CS 5x80 1 x CS 8x80	2 x CS 5x50 1 x CS 8x50	8,4	6,3
1 stirrup: $F_{3,Rk} = 2,7$ kN				2 stirrups: $F_{3,Rk} = 5,15$ kN	

Minimum timber cross section : 50 x 80 mm

RICON® 80/40

Characteristic values for dimensioning can be taken from the ETA Static Folder.

Minimum timber cross section

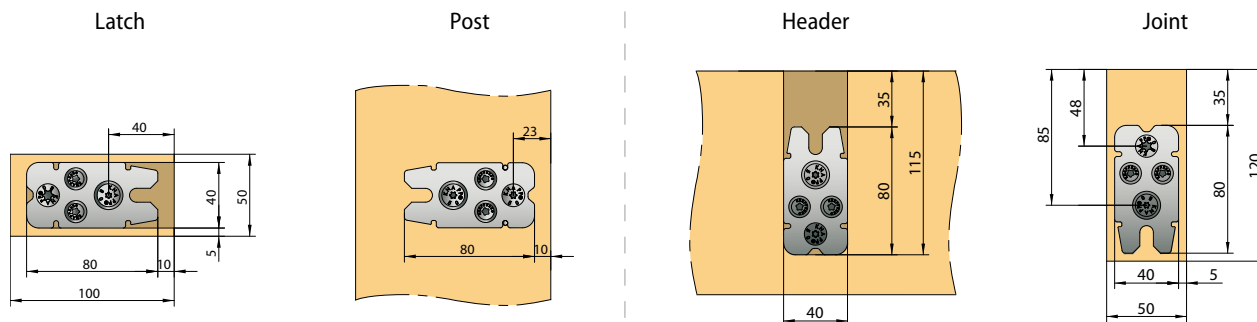

Minimum timber width: 50 mm

Minimum timber width: 60 mm

Single connection (EA) with RICON® CS-screws

Art.-No. K361

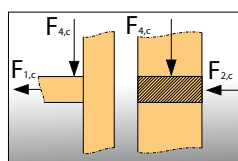

Single connection for post and latch connection with a minimum timber cross section of 50 mm (stress at mid to the axis of latch)

Connector	Connection	Screwing		Charact. values [GL24h]	
		Joint	Header	$F_{1,Rk}$ [kN]	$F_{2,Rk}$ [kN]
80/40	EA	2 x CS 5x80 2 x CS 8x80	2 x CS 5x50 2 x CS 8x50	8,4	10,3
1 stirrup: $F_{3,Rk} = 2,7$ kN				2 stirrups: $F_{3,Rk} = 5,4$ kN	

Minimum timber cross section : 50 x 100 mm

RICON® 100/40

Characteristic values for dimensioning can be taken from the ETA Static Folder.

Minimum timber cross section

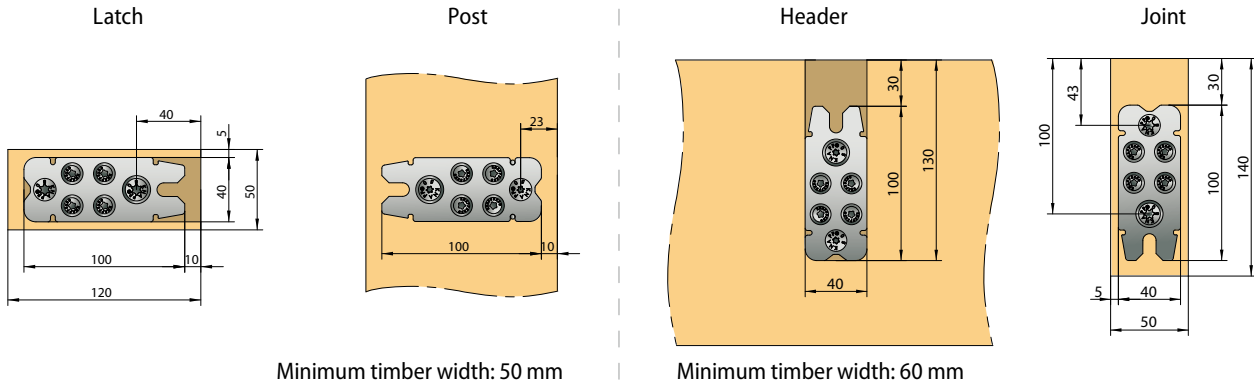

Single connection (EA) with RICON® CS-screws

Art.-No. K362

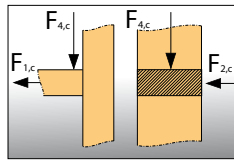

Single connection for post and latch connection with a minimum timber cross section of 50 mm (stress at mid to the axis of latch)

Connector	Connection	Screwing		Charact. values [GL24h]	
		Joint	Header	F _{1,Rk} [kN]	F _{2,Rk} [kN]
100/40	EA	4 x CS 5x80 2 x CS 8x80	4 x CS 5x50 2 x CS 8x50	8,4	15,4
1 stirrup: F _{3,Rk} = 2,7 kN				2 stirrups: F _{3,Rk} = 5,4 kN	

Minimum timber cross section : 50 x 120 mm

RICON® 120/40

Characteristic values for dimensioning can be taken from the ETA Static Folder.

Minimum timber cross section

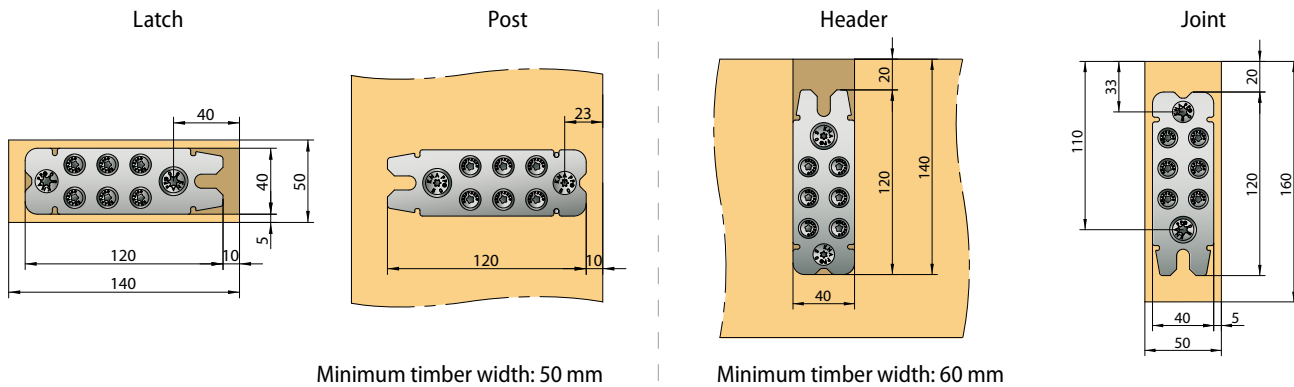

Single connection (EA) with RICON® CS-screws

Art.-No. K363

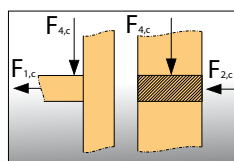

Single connection for post and latch connection with a minimum timber cross section of 50 mm (stress at mid to the axis of latch)

Connector	Connection	Screwing		Charact. values [GL24h]	
		Joint	Header	F _{1,Rk} [kN]	F _{2,Rk} [kN]
120/40	EA	6 x CS 5x80 2 x CS 8x80	6 x CS 5x50 2 x CS 8x50	8,4	19,7
1 stirrup: F _{3,Rk} = 2,7 kN				2 stirrups: F _{3,Rk} = 5,4 kN	

Minimum timber cross section : 50 x 140 mm

RICON® 140/40

Characteristic values for dimensioning can be taken from the ETA Static Folder.

Minimum timber cross section

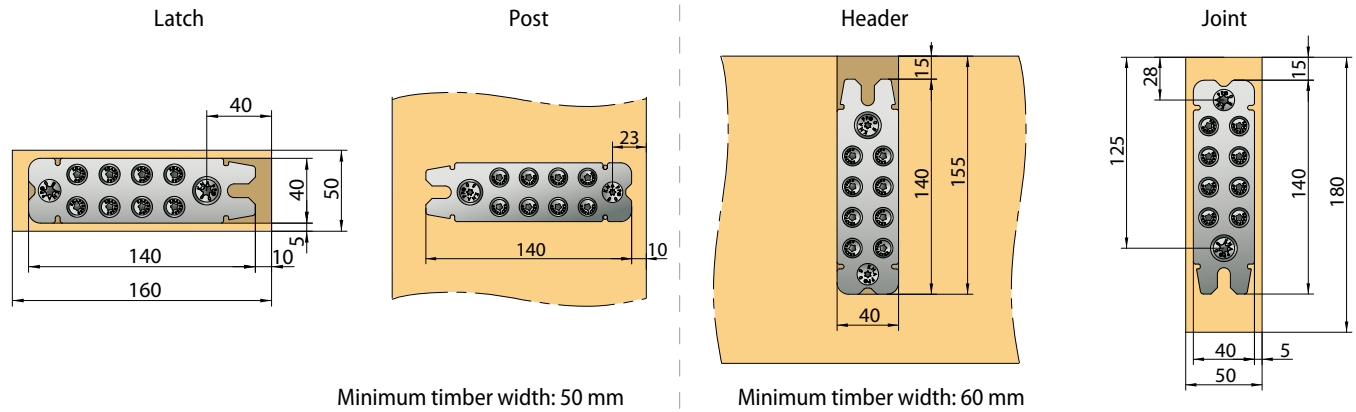

Single connection (EA) with RICON® CS-screws

Art.-No. K365

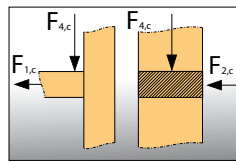

Single connection for post and latch connection with a minimum timber cross section of 50 mm (stress at mid to the axis of latch)

Connector	Connection	Screwing		Charact. values [GL24h]	
		Joint	Header	F _{1,Rk} [kN]	F _{2,Rk} [kN]
140/40	EA	8 x CS 5x80 2 x CS 8x80	8 x CS 5x50 2 x CS 8x50	8,4	24,1
		1 stirrup: F _{3,Rk} = 2,7 kN		2 stirrups: F _{3,Rk} = 5,4 kN	

Minimum timber cross section : 50 x 160 mm

RICON® 160/40

Characteristic values for dimensioning can be taken from the ETA Static Folder.

Minimum timber cross section

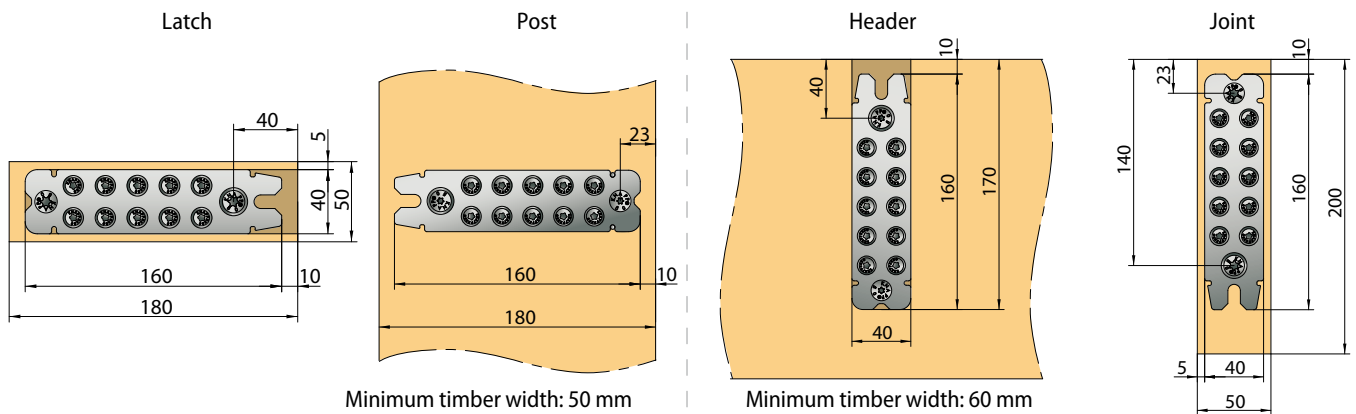

Single connection (EA) with RICON® CS-screws

Art.-No. K364

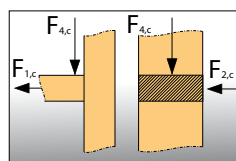

Single connection for post and latch connection with a minimum timber cross section of 50 mm (stress at mid to the axis of latch)

Connector	Connection	Screwing		Charact. values [GL24h]	
		Joint	Header	F _{1,Rk} [kN]	F _{2,Rk} [kN]
160/40	EA	10 x CS 5x80 2 x CS 8x80	10 x CS 5x50 2 x CS 8x50	8,4	26,0
		1 stirrup: F _{3,Rk} = 2,7 kN		2 stirrups: F _{3,Rk} = 5,4 kN	

Minimum timber cross section : 50 x 160 mm

RICON®

Pre-dimensioning for header and joint

Minimum timber cross section for joint for RICON® connection in reference to uniformly distributed load q_k and span L for solid timber C24 and glued laminated timber GL24h.

Applications for roofs, rafters and rafter latches:

(Use class 1-2, class of exposure time KLED: Short to medium):

Ratio of dead load to total load: $g_k/q_k = 0,4$

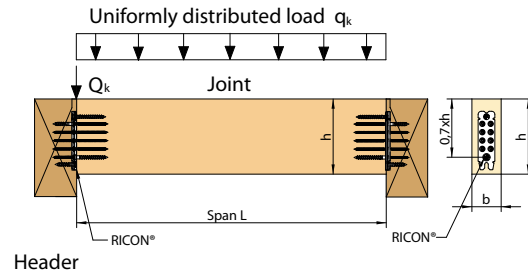

Span L	Uniformly distributed load q_k			
	$q_k = 1,00 \text{ kN/m}$	$q_k = 1,50 \text{ kN/m}$	$q_k = 2,00 \text{ kN/m}$	$q_k = 2,50 \text{ kN/m}$
	Cross timber section w/l [cm/cm]	Cross timber section w/l [cm/cm]	Cross timber section w/l [cm/cm]	Cross timber section w/l [cm/cm]
	RICON®	RICON®	RICON®	RICON®
1,00 m	5/12 60/40	5/12 60/40	5/12 60/40	5/12 60/40
1,50 m	5/12 60/40	5/12 60/40	5/12 80/40	5/12 80/40
2,00 m	5/12 60/40	5/12 80/40	5/12 80/40	5/14 80/40
2,50 m	5/12 80/40	5/14 80/40	5/16 80/40	5/16 100/40
3,00 m	5/14 80/40	5/16 80/40	5/18 100/40	5/20 120/40
3,50 m	5/18 80/40	5/20 100/40	6/20 100/40	6/22 120/40
4,00 m	6/18 100/40	6/20 100/40	6/22 120/40	6/24 140/40
4,50 m	6/20 100/40	6/24 120/40	6/26 120/40	8/26 140/40
5,00 m	6/22 120/40	6/26 120/40	8/26 140/40	8/28 160/40
5,50 m	6/24 120/40	8/26 120/40	8/28 140/40	10/28 160/40
6,00 m	8/24 120/40	8/28 140/40	10/28 160/40	

Span L	Uniformly distributed load q_k			
	$q_k = 3,00 \text{ kN/m}$	$q_k = 3,50 \text{ kN/m}$	$q_k = 4,00 \text{ kN/m}$	$q_k = 4,50 \text{ kN/m}$
	Cross timber section w/l [cm/cm]	Cross timber section w/l [cm/cm]	Cross timber section w/l [cm/cm]	Cross timber section w/l [cm/cm]
	RICON®	RICON®	RICON®	RICON®
1,00 m	5/12 80/40	5/12 80/40	5/12 80/40	5/12 80/40
1,50 m	5/12 80/40	5/14 80/40	5/14 100/40	5/16 100/40
2,00 m	5/16 100/40	5/16 100/40	5/18 120/40	5/20 120/40
2,50 m	6/16 120/40	6/18 120/40	6/20 140/40	6/20 140/40
3,00 m	6/20 120/40	6/22 140/40	6/22 160/40	6/24 160/40
3,50 m	6/22 140/40	6/24 160/40	8/22 160/40	
4,00 m	6/26 160/40	8/24 160/40		

The load values from the index refer to stress in thrust direction only. The minimum cross section timber of the latch refers to solid timber C24. The given values of RICON® connectors are including a main load q_k of 1,0 kN straight to the end of the joint where it is connected to the header. Detailed information for the structural analysis are given in the ETA STATICS FOLDER. Further information at: www.knapp-connectors.com/download.



RICON® DA / EAR for all sizes

Double connection with connecting nuts and RICON® CS-screws

DA



Single- or dual connection with insert and RICON® CS-screws

EAR



More Information:
www.knapp-connectors.com/ricon

RICON® screws

RICON® CS-screws with reinforced shaft and cut-point
 (CS-screws are included with delivery)

Art.-No. Z533 CS-screws 5x50
 Art.-No. Z531 CS-screws 8x50

Application: For longitudinal screwing of RICON® connectors (post).

Art.-No. Z534 CS-screws 5x80
 Art.-No. Z532 CS-screws 8x80

Application: For end grain screwing of RICON® connectors (latch).

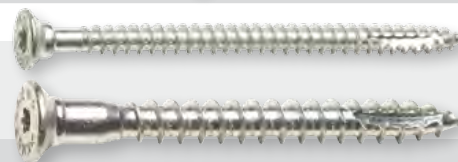
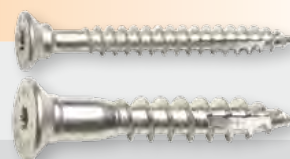

CS-screws RICON® DA

Art.-No. Z545 CS-screw M5x20 (for RICON® 60/40 DA)
 Art.-No. Z548 CS-screw M8x25

Application: For screwing RICON® double connections (DA).

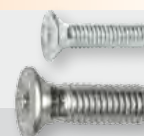

Connecting nuts RICON® DA

(Connecting nuts are included with delivery)

Art.-No. K540	Connecting nut M5 8x48	50 mm post thickness
Art.-No. K541	Connecting nut M5 8x53	55 mm post thickness
Art.-No. K542	Connecting nut M5 8x58	60 mm post thickness
Art.-No. K543	Connecting nut M5 8x78	80 mm post thickness



Utilisation : For screwing RICON® 60/40 double connections (DA).

Art.-No. K544	Connecting nut M8 10x36	<50 mm post thickness
Art.-No. K545	Connecting nut M8 10x48	50 mm post thickness
Art.-No. K546	Connecting nut M8 10x53	55 mm post thickness
Art.-No. K547	Connecting nut M8 10x58	60 mm post thickness
Art.-No. K548	Connecting nut M8 10x68	70 mm post thickness
Art.-No. K549	Connecting nut M8 10x78	80 mm post thickness



Application: For screwing RICON® double connections (DA).

Inserts RICON® EAR

(Inserts are included with delivery)

Art.-No. K540 Insert M5x14 pour RICON® 60/40
 Art.-No. K541 Insert M8x18

Application: For special sizes of posts.



RICON® Accessories

Routing-jig for all RICON® sizes

Art.-No. K502 Routing-jig MULTI F40 (plywood)

Advice: The routing-jig MULTI F is suitable for a $\varnothing = 30$ mm guide bush (for plunge router) and a $\varnothing = 15$ mm TCT router cutter.

Application: For milling for concealed mounting.

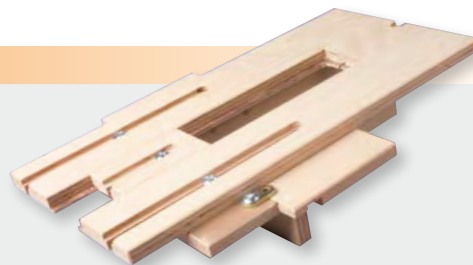

Drilling-jig RICON® EA/DA (galvanized steel)

Art.-No.	K621	K622	K623	K624	K629	K630
	60/40	80/40	100/40	120/40	140/40	160/40

Application: For installation into the drilling-jig and exact pre-drilling of the positioning screws.



HM router cutter

Art.-No. Zo66 HM router cutter $\varnothing = 15$, length = 25 mm with $\varnothing = 8$ mm shank

Application: To recess the rebate for RICON® and GIGANT.



Stirrup RICON® (stainless spring steel stirrup)

Art.-No. Ko64 Stirrup RICON®

Application: The stirrup locks the connection against slide-in direction. It can be released on request.



Drilling-jig RICON® EA/DA for post-latch connections

Art.-No.	K634	K635	K636	K637	K638	K639
	60/40 Set	80/40	100/40	120/40	140/40	160/40

Drilling-jig RICON® EA/DA for header-joint connections

Art.-No.	K634	K642	K643	K644	K645	K646
	60/40 Set	80/40	100/40	120/40	140/40	160/40

Application: With this the positioning and through-hole drilling are made.



Drilling-jig RICON® with adjustable drilling blocks

Art.-No.	-	K647	K647	K647	K647	K647
----------	---	------	------	------	------	------

Drilling blocks:	-	80/40	100/40	120/40	140/40	160/40
------------------	---	-------	--------	--------	--------	--------

Application: With this the positioning and through-hole drilling are made.

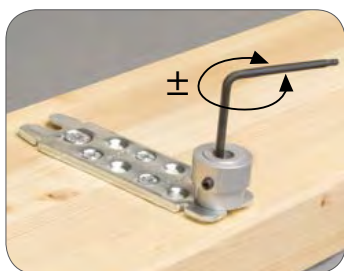
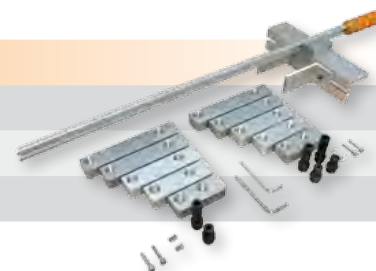

RICON® mounting set

Art.-No. Ko65 Consisting of: 1 RICON®-depth gauge
incl. 1 Torx wrench T25 combined with allen key SW5

Application: For fine adjustment of RICON® screws.



RICON®

Installation

- Simple and fast installation with spindle moulder or routing machine and optional KNAPP® template.
- Installation with CNC joinery machine possible – all data for the standard CNC joinery machine programmes are included.



CNC joinery machine



1) With the routing-jig or routing machine on the bolt a 40 mm wide and 12 mm deep milling will be made (Length according to the assembly instructions).



2) The drilling-jig will be inserted and pre-drilled.



3) Connector parts screw on mirrored.



4) The retaining screw is turned up to the shoulder to stop. With the depth gauge the retaining screw is adjusted rationally. Also during the installation process the adjustment of the gap can be guaranteed.



5) Assembly: The connection is made by simply pushing together. At this point the locking clip will lock (if fitted).

Stirrup: Depending on static requirements, the stirrup can be inserted on one or on both sides. If the connection is accessible, it can be unlocked (6).



6) To unlock the connection, it is necessary to bend up the stirrup in his center e.g. with a screwdriver.

Routing dimension RICON®		
Width	Length	Depth
40 mm	variable	12 mm

Alternatively, the milling done at a sufficient cross section and in the post - in this case (left), the connector is screwed on the bolt.



Construction manuals, .DXF drawings for RICON®-System as well as your personal consultant in your area, please visit: www.knapp-connectors.com/download



GIGANT | The connector for main and secondary beam up to 29,8 kN*

System advantages:

- Highly loadable – in all directions
- Timber width from 60 mm upwards
- Short hooking way – applications for porch, pergola, sun room and prefabricated house construction
- Joint sealant – self-tightening by permanent pressure
- Fire resistance (DIN 4102-2) by 4-sided concealed mounting (R₃₀ ≥ 20 mm, R₆₀ ≥ 40 mm)
- Optional locking clip – saves against the hooking direction (e.g. wind suction)
- Dismounting and remounting possible for several times
- **NEW:** ETA additionally with hardwood material



Installation example:
Screw on the main and secondary beams.



Dove-tail for an easy positioning. The starting angle brings the connector into tension and offers an easy mounting.

10 mm KNAPP® CS-screws with cut point for extra fast screwing and the reinforced shaft enables a force-locked connection.

The clip lock offers an optional locking against direction of insertion.

GIGANT is made of premium quality steel, is blue galvanised and produced in Austria. Optional available with hot-dip galvanizing.



Variants

The GIGANT is blue galvanised delivered.



Resistance to corrosion:

For GIGANT a special coating is obtainable on request (for example near coastal areas).

 **More information:**
www.knapp-connectors.com/gigant

*Charact. load carrying capacity $F_{z,Rk}$ in insertion direction applies only to the use of original KNAPP® cs-screws according to ETA 10/0189.

GIGANT

Connection options

The GIGANT offers three different mounting options and these can be used both on main or secondary beam.

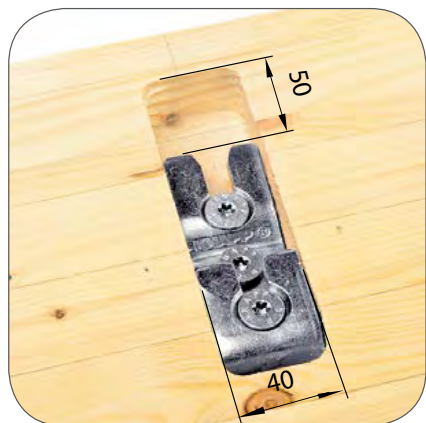

Hidden 4-sided

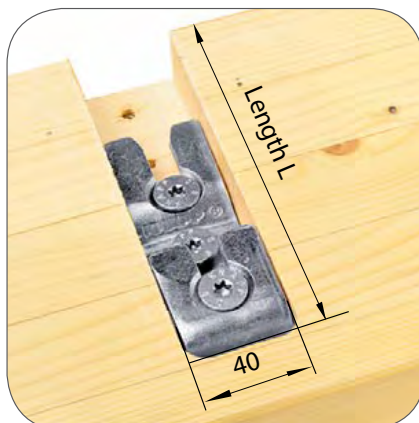

Hidden 3-sided



Visible



Position



Screw on



Locks after hooking against the insertion direction



Recommended software partners for machine processing:



GIGANT 120/40

Characteristic values for dimensioning can be taken from the ETA Static Folder.

Application examples and connection details

Art.-No. K051

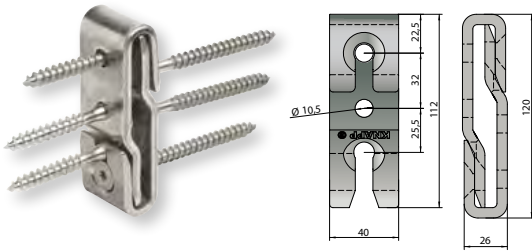

Connector	Connection	Screwing		Charact. values [GL24h]	
		Joint	Header	$F_{2,Rk}$ [kN]	$F_{45,Rk}$ [kN]
120/40	without clip lock	3 x CS 10x120	3 x CS 10x80	12,7	11,8
120/40	with clip lock	3 x CS 10x120	3 x CS 10x80	12,7	11,8

Clip lock: $F_{3,Rk} = 11,0$ kN

Minimum timber cross section **with/without clip lock**: 60 x 150 mm

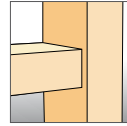

Single connection for post-latch connections

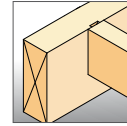

Single connection:
Header thickness from 100 mm;
Joint thickness from 60 mm
with cliplock (80 mm without)

GIGANT 150/40

Characteristic values for dimensioning can be taken from the ETA Static Folder.

Application examples and connection details

Art.-No. K050

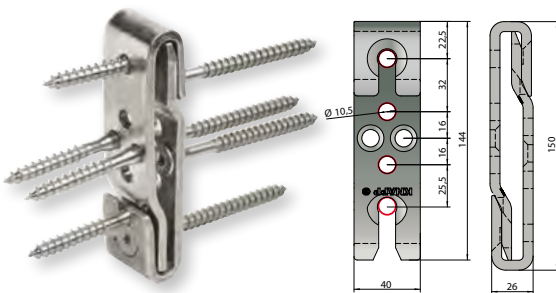

Standard screwing
without clip lock.

Screwing in the middle
by using the clip lock.

Connector	Connection	Screwing		Charact. values [GL24h]	
		Joint	Header	$F_{2,Rk}$ [kN]	$F_{45,Rk}$ [kN]
150/40	without clip lock	4 x CS 10x120	4 x CS 10x80	19,6	13,0
150/40	with clip lock	4 x CS 10x120	4 x CS 10x80	19,8	15,7

Clip lock: $F_{3,Rk} = 12,0$ kN

Minimum timber cross section **without clip lock**: 80 x 200 mm

Minimum timber cross section **with clip lock**: 60 x 200 mm

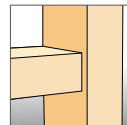

Single connection for post-latch connections

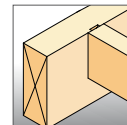

Single connection:
Header thickness from 100 mm;
Joint thickness from 60 mm
with cliplock (80 mm without)

GIGANT 180/40

Characteristic values for dimensioning can be taken from the ETA Static Folder.

Application examples and connection details

Art.-No. K052

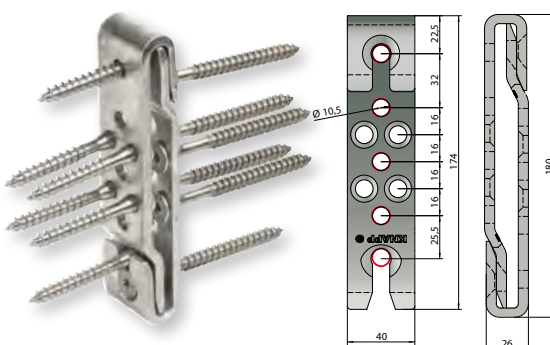

Standard screwing
without clip lock.

Screwing in the middle
by using the clip lock.

Connector	Connection	Screwing		Charact. values [GL24h]	
		Joint	Header	$F_{2,Rk}$ [kN]	$F_{45,Rk}$ [kN]
180/40	without clip lock	6 x CS 10x120	6 x CS 10x80	29,8	20,1
180/40	with clip lock	5 x CS 10x120	6 x CS 10x80	24,8	21,0

Clip lock: $F_{3,Rk} = 12,0$ kN

Minimum timber cross section **without clip lock**: 80 x 220 mm

Minimum timber cross section **with clip lock**: 60 x 220 mm

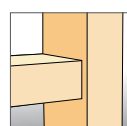

Single connection for post-latch connections

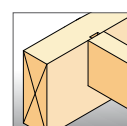

Single connection:
Header thickness from 100 mm;
Joint thickness from 60 mm
with cliplock (80 mm without)

GIGANT

Pre-dimensioning for header and joint

Minimum timber cross section for GIGANT connection in reference to line load q and span L for glued laminated timber GL24h and solid timber C24 according DIN 1052 (release 2008) and Eurocode 5.

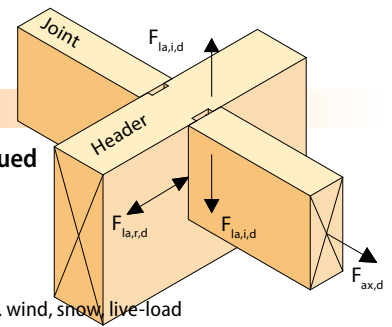

Roofs, rafters, rafter latches

(service classes 1-2, load-duration class: **short-term**) Dead-load g_k (40%) e. g. self-weight and alternating load q_k (60%) e. g. wind, snow, live-load

Span L	Uniformly distributed load q_k			
	$q_k = 2,00 \text{ kN/m}$	$q_k = 3,00 \text{ kN/m}$	$q_k = 4,00 \text{ kN/m}$	$q_k = 4,50 \text{ kN/m}$
	Cross timber section w/l [cm/cm] GIGANT	Cross timber section w/l [cm/cm] GIGANT	Cross timber section w/l [cm/cm] GIGANT	Cross timber section w/l [cm/cm] GIGANT
2,00 m	6/16 120/40	6/16 120/40	6/16 120/40	6/16 120/40
3,00 m	6/16 120/40	6/18 120/40	6/20 150/40	8/20 150/40
4,00 m	8/20 150/40	8/22 150/40	8/24 180/40	10/24 180/40
5,00 m	8/24 150/40	10/26 180/40	10/28 180/40	12/28 180/40
6,00 m	8/28 180/40	10/30 180/40	12/32 180/40	12/32 180/40

Residential building, ceilings

(service classes 1-2, load-duration class: **medium-term**) Dead-load g_k (40%) e. g. self-weight and alternating load q_k (60%) e. g. wind, snow, live-load

Span L	Uniformly distributed load q_k			
	$q_k = 2,00 \text{ kN/m}$	$q_k = 3,00 \text{ kN/m}$	$q_k = 4,00 \text{ kN/m}$	$q_k = 4,50 \text{ kN/m}$
	Cross timber section w/l [cm/cm] GIGANT	Cross timber section w/l [cm/cm] GIGANT	Cross timber section w/l [cm/cm] GIGANT	Cross timber section w/l [cm/cm] GIGANT
2,00 m	6/16 120/40	6/16 120/40	6/16 120/40	6/16 120/40
3,00 m	6/16 120/40	6/20 120/40	8/20 150/40	8/20 150/40
4,00 m	8/20 150/40	8/22 150/40	10/22 180/40	10/24 180/40
5,00 m	8/24 150/40	10/26 180/40	10/28 180/40	12/28 180/40
6,00 m	10/26 180/40	10/30 180/40	12/32 180/40	

Storage building, ceilings

(service classes 1-2, load-duration class: **long-term**) Dead-load g_k (40%) e. g. self-weight and alternating load q_k (60%) e. g. wind, snow, live-load

Span L	Uniformly distributed load q_k			
	$q_k = 2,00 \text{ kN/m}$	$q_k = 3,00 \text{ kN/m}$	$q_k = 4,00 \text{ kN/m}$	$q_k = 4,50 \text{ kN/m}$
	Cross timber section w/l [cm/cm] GIGANT	Cross timber section w/l [cm/cm] GIGANT	Cross timber section w/l [cm/cm] GIGANT	Cross timber section w/l [cm/cm] GIGANT
2,00 m	6/16 120/40	6/16 120/40	6/16 120/40	6/16 120/40
3,00 m	6/16 120/40	6/20 120/40	8/20 150/40	8/22 150/40
4,00 m	8/20 150/40	8/24 150/40	10/24 180/40	10/26 180/40
5,00 m	8/24 150/40	10/26 180/40	10/30 180/40	
6,00 m	10/26 180/40	10/32 180/40		

The table values are only to be applied for loading in direction of insertion. The minimum cross section of the secondary beam is calculated for timber C24 (S10).

For the connection force of GIGANT, the live load over the bearing was set to 1,0 kN (man load upon the bearing).

Detailed information for static calculation are to be found in the ETA Static Folder. Find more information at www.knapp-verbinder.com/download

GIGANT screws

KNAPP® CS-screws (with reinforced shaft and cut-point)
(GIGANT is being delivered with suitable CS-screws)

Art.-No. Z523 CS-screw 10x80
Art.-No. Z524 CS-screw 10x120 (Plywood)



Application: For screwing the GIGANT on the header (post) e.g. joint (latch).

GIGANT Accessories

Routing-jig for all GIGANT sizes

Art.-No. K502 Routing-jig MULTI F40 (plywood)

Advice: The routing-jig MULTI F is suitable for a $\varnothing = 30$ mm guide bush (for plunge router) and a $\varnothing = 15$ mm TCT router cutter.

Application: For milling in concealed mounting.



GIGANT

TCT router cutter

Art.-No. Z068 TCT router cutter $\varnothing = 15$ mm, Length = 40 mm with $\varnothing = 12$ mm shank

Application: To recess the rebate.



GIGANT

Drilling-jig GIGANT (galvanized steel)

Art.-No. K631 Drilling-jig GIGANT 120
Art.-No. K632 Drilling-jig GIGANT 150
Art.-No. K633 Drilling-jig GIGANT 180



Application: For installation into the drilling-jig and exact pre-drilling of the positioning screws.

GIGANT

Drilling-jig GIGANT (adjustable)

Art.-No. K463 Drilling-jig GIGANT 120
Art.-No. K464 Drilling-jig GIGANT 150
Art.-No. K465 Drilling-jig GIGANT 180

Jig with hardened drill bushes for $\varnothing = 6$ mm

Application: For the exact predrilling of the positioning screws.

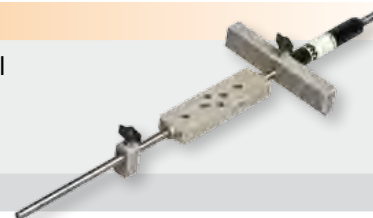

GIGANT

Clip lock GIGANT (galvanized steel plate)

Art.-No. Z525 Clip lock GIGANT

Application: Locks against unhinge and is resilient against the insertion direction such as wind suction.

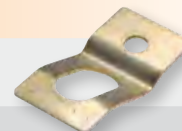

Functionality of clip lock

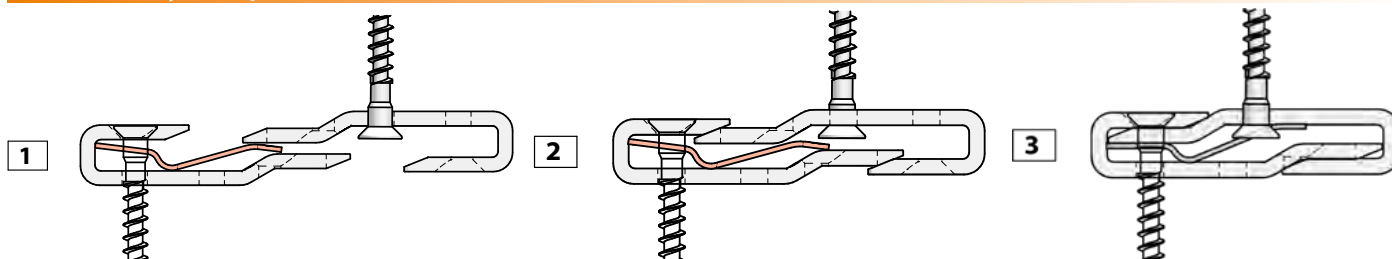

GIGANT

Installation

- | Installation with CNC joinery machine possible – all data for the standard CNC joinery machine programmes are included.
- | Routing machine with KNAPP® routing-jig.



1) Routing



2) Pre-drilling header



3) Screw on



4) Predrilling joint



5A) Screw on counterpart



5b) Optional screw with clip lock

Routing dimension GIGANT		
Width	Length	Depth
40 mm	variabel	26,5 mm



6) Assemble

Construction manuals, .DXF drawings for GIGANT-System as well as your personal consultant in your area, please visit: www.knapp-connectors.com/download

Recommended software partners for machine processing:





RICON® S | The connector for main and secondary beam up to 100 kN*

System advantages:

- | Connector for timber frame, wood frame buildings and halls
- | Timber width from 100 mm upwards
- | Universally applicable to timber, steel or concrete
- | Simple screwing without predrilling
- | Easy hooking by large V-shaping – only 3,5 cm hooking way
- | Three- and four-sided concealed connection
- | High fire resistance through three- and four-sided concealed mounting
- | Adjustable collar bolt up to 5mm length tolerance at full load capacity
- | Optional – securing against the insertion direction with clip lock
- | **NEW:** ETA additionally with hardwood material

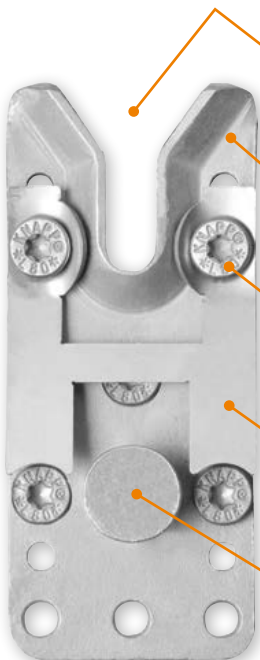

The V-shape moulding provides perfect catch of the collar bolt. The strong tension and the short slide-in alleviates the connecting and guarantees joint sealing.

RICON® S is made of premium quality steel, hot-dip galvanized and produced in Germany.

KNAPP® CS-screws with cut point for extra fast starts and screwing. The reinforced shaft provides force-fit connection.

The RICON® S clip lock, made from stainless spring steel, locks the connection against slide-in direction and can optionally be used for stress against slide-in direction or wind suction.

There are different versions of the collar bolt available for RICON® S which offers four different connection options.



RICON® S60 VS
140x60x25

RICON® S60 VS
200x60x25



RICON® S80 VS
200x80x25

RICON® S80 VS
290x80x25



More information:
www.knapp-connectors.com/ricons

*Charact. load carrying capacity $F_{z,Rk}$ in insertion direction applies only to the use of original KNAPP® cs-screws according to ETA 10/0189.

RICON® S

Application examples and connection details

Ridged roof with purlins and latch connections

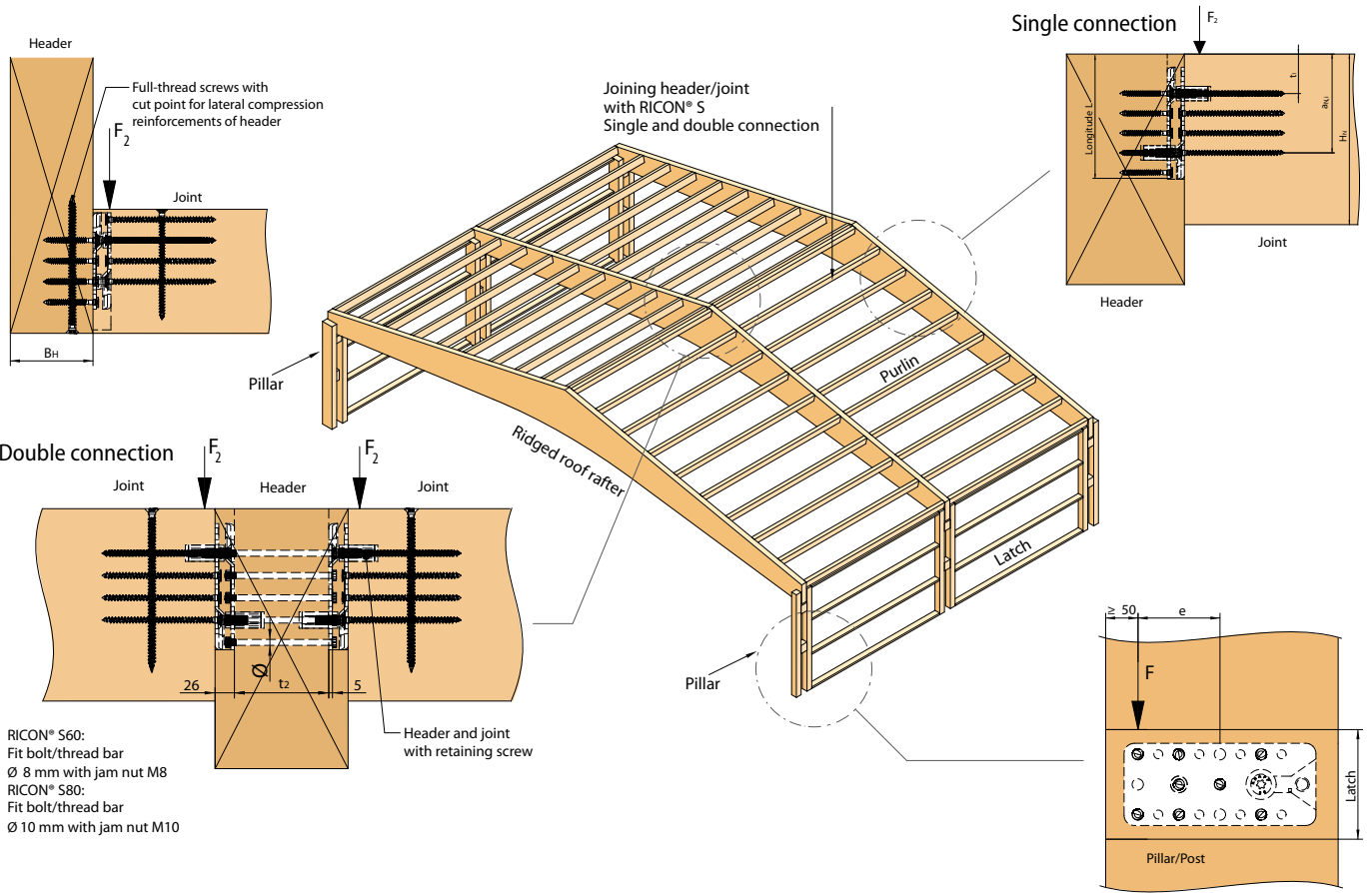

Hall roof of carpentry S. Hinrichsen (Germany)

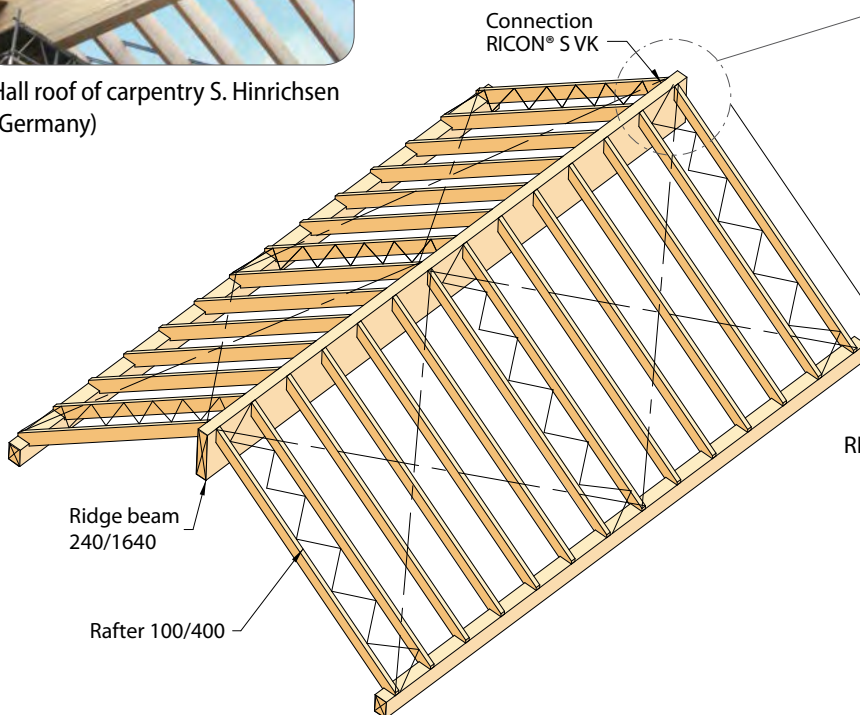

RICON® S housed into a rafter

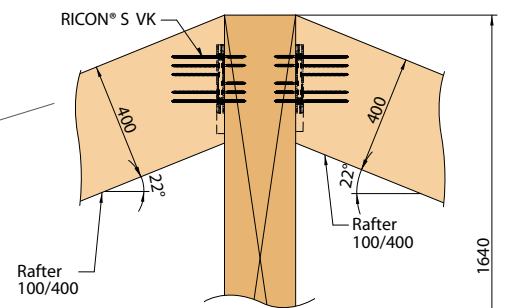

RICON® S housed into the ridge beam

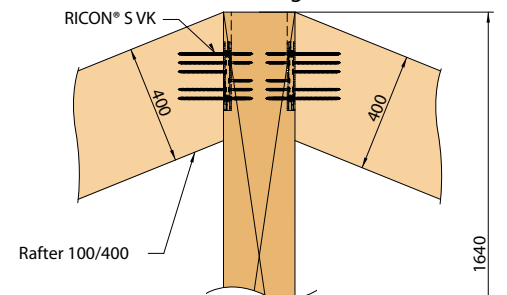

(All dimensions in mm)

RICON® S

Application prefabricated houses

Connecting header with timber frame construction or cross-laminated timber wall

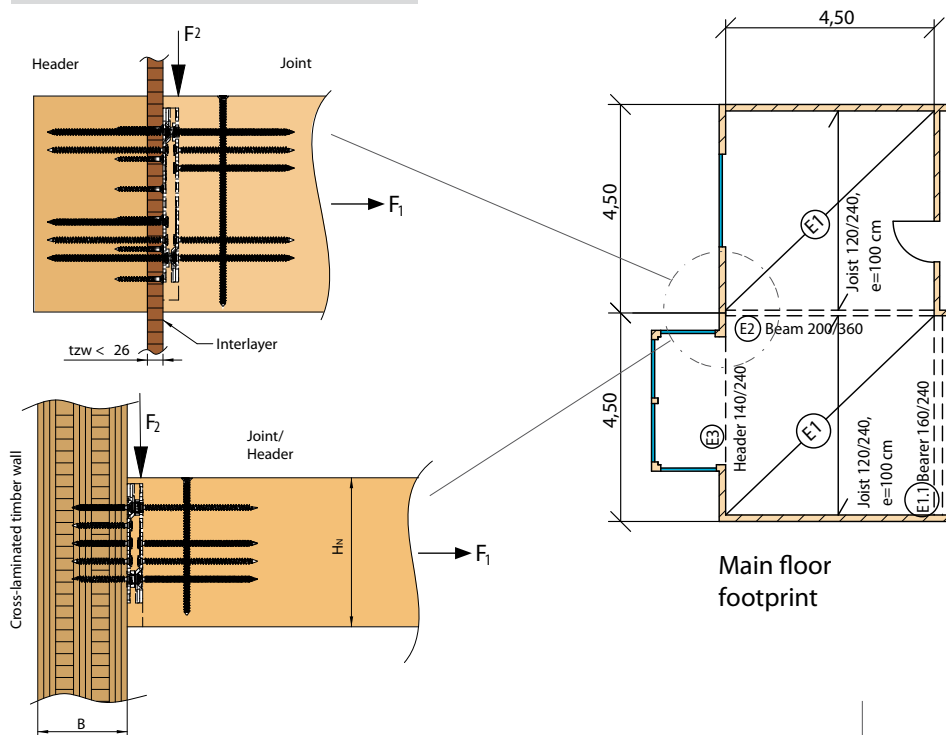

Steel connection



First node for dome

Ceiling of a timber frame construction

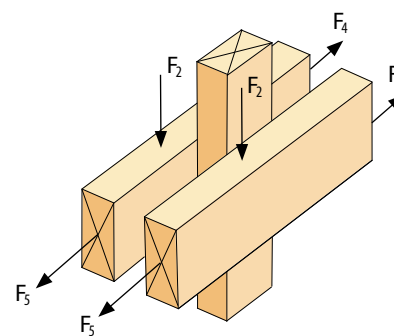
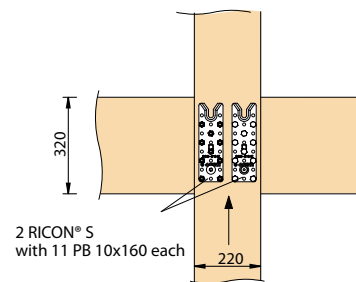
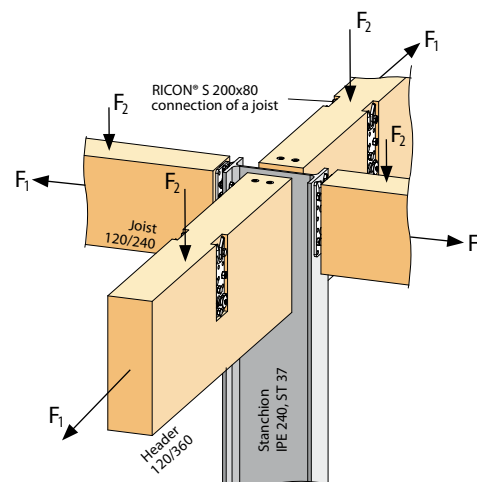
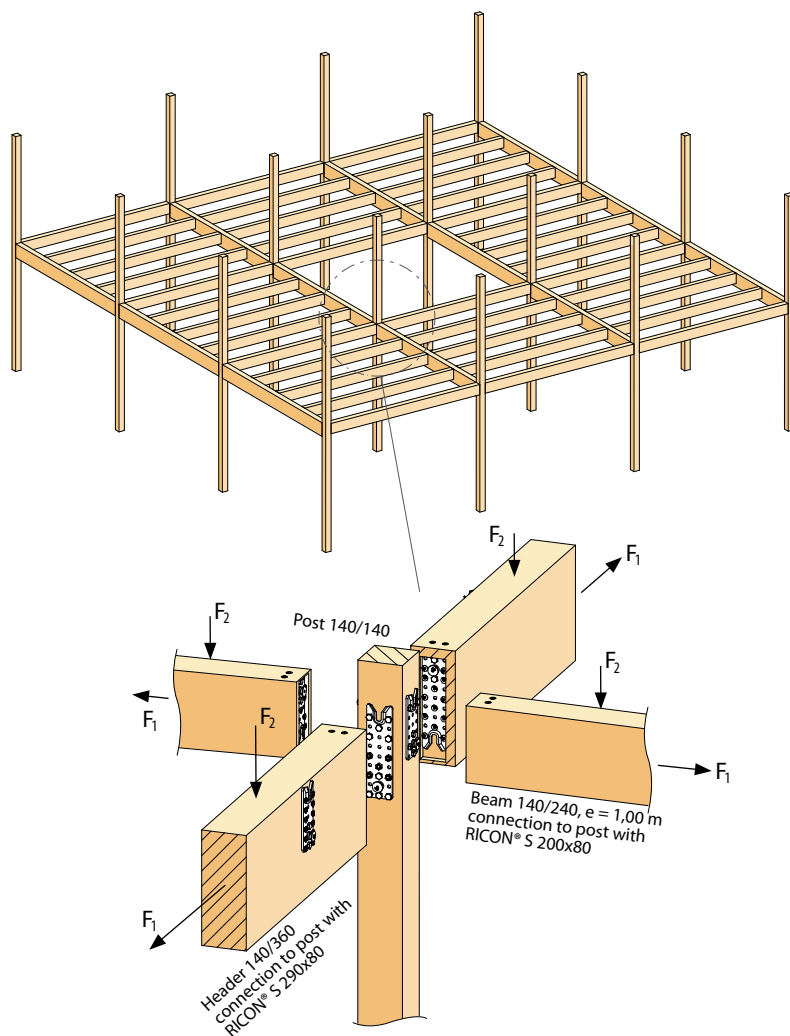

Alternative ways to connect

RICON® S60

Characteristic values for dimensioning can be taken from the ETA Static Folder.

RICON® S 140/60 - Collar bolts and screwing

Art.-No. VS: K126 / VK: K130 / EK: K146 / GK: K134

Header Joint

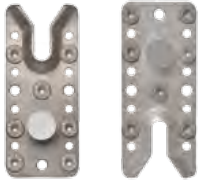

Minimum screwing: n = 7

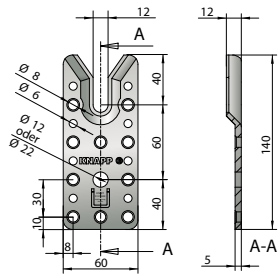

Connector	Collar bolt	Screwing		Charact. values [GL24h] F _{2,Rk} [kN]
		Joint	Header	
140/60	VS	10 x CS 8x160	10 x CS 8x80	53,0
140/60	VK D12	8 x CS 8x160	8 x CS 8x80	39,8
Available on request:				
140/60	EK M12	7 x CS 8x160	7 x CS 8x80	36,0
140/60	GK M12	7 x CS 8x160	7 x CS 8x80	36,0
Clip lock: F _{3,Rk} = 18,0 kN				

Minimum timber cross section: 100 x 160 mm

RICON® S 200/60 - Collar bolts and screwing

Art.-No. VS: K127 / VK: K132 / EK: K148 / GK: K136

Header Joint



Minimum screwing: n = 8

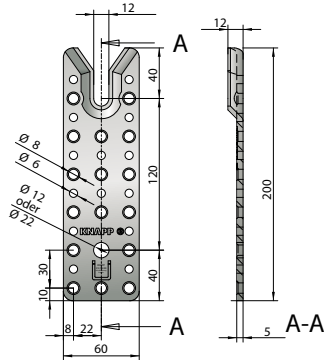

Connector	Collar bolt	Screwing		Charact. values [GL24h] F _{2,Rk} [kN]
		Joint	Header	
200/60	VS	16 x CS 8x160	16 x CS 8x80	60,0
200/60	VK D12	9 x CS 8x160	9 x CS 8x80	49,7
Available on request:				
200/60	EK M12	8 x CS 8x160	8 x CS 8x80	44,7
200/60	GK M12	8 x CS 8x160	8 x CS 8x80	44,7
Clip lock: F _{3,Rk} = 18,0 kN				

Minimum timber cross section: 100 x 220 mm

RICON® S80

Characteristic values for dimensioning can be taken from the ETA Static Folder.

RICON® S 200/80 - Collar bolts and screwing

Art.-No. VS: K128 / VK: K138 / EK: K153 / GK: K142

Header Joint



Minimum screwing: n = 8

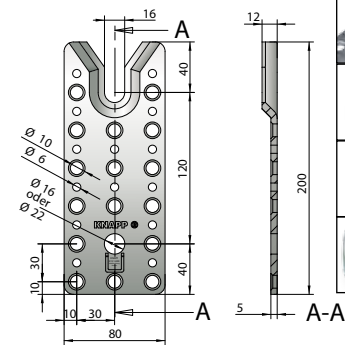

Connector	Collar bolt	Screwing		Charact. values [GL24h] F _{2,Rk} [kN]
		Joint	Header	
200/80	VS	16 x CS 10x200	16 x CS 10x100	100
200/80	VK D16	9 x CS 10x200	9 x CS 10x100	70,5
Available on request:				
200/80	EK M16	8 x CS 10x200	8 x CS 10x100	63,0
200/80	GK M16	8 x CS 10x200	8 x CS 10x100	63,0
Clip lock: F _{3,Rk} = 18,0 kN				

Minimum timber cross section: 120 x 230 mm

RICON® S 290/80 - Collar bolts and screwing

Art.-No. VS: K129 / VK: K141 / EK: K156 / GK: K145

Header Joint

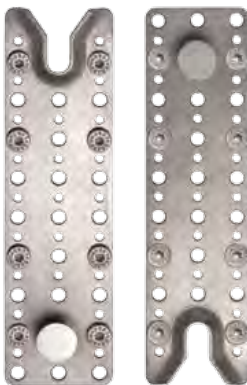

Minimum screwing: n = 8

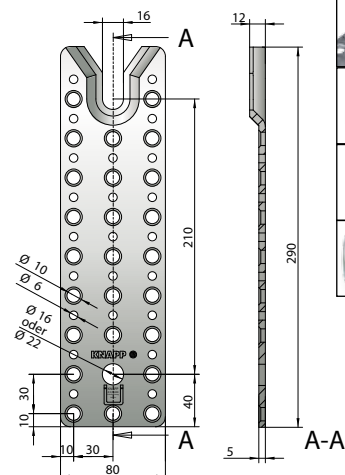

Connector	Collar bolt	Screwing		Charact. values [GL24h] F _{2,Rk} [kN]
		Joint	Header	
290/80	VS	20 x CS 10x200	20 x CS 10x100	100
290/80	VK D16	9 x CS 10x200	9 x CS 10x100	70,5
Available on request:				
290/80	EK M16	8 x CS 10x200	8 x CS 10x100	63,0
290/80	GK M16	8 x CS 10x200	8 x CS 10x100	63,0
Clip lock: F _{3,Rk} = 18,0 kN				

Minimum timber cross section: 120 x 320 mm

RICON® S

Pre-dimension

Minimum timber cross section for joint for RICON® S connection in reference to uniformly distributed load q_k and span L for glued laminated timber and GL 24 h according DIN 1052 (release 2008) and Eurocode 5

Roofs, rafters, rafter latches

(service classes 1-2, load-duration class: **short-term**) Dead-load g_k (40%) e. g. self-weight and alternating load q_k (60%) e. g. wind, snow, live-load

Span L	Uniformly distributed load q_k					
	$q_k = 3,00 \text{ kN/m}$	$q_k = 4,00 \text{ kN/m}$	$q_k = 5,00 \text{ kN/m}$	$q_k = 6,00 \text{ kN/m}$	$q_k = 7,00 \text{ kN/m}$	$q_k = 8,00 \text{ kN/m}$
	Cross timber section w/l [cm/cm]	Cross timber section w/l [cm/cm]	Cross timber section w/l [cm/cm]	Cross timber section w/l [cm/cm]	Cross timber section w/l [cm/cm]	Cross timber section w/l [cm/cm]
	RICON® S	RICON® S	RICON® S	RICON® S	RICON® S	RICON® S
4,00 m	10/20 140/60	10/22 140/60	10/24 200/60	10/26 200/80	12/26 200/80	12/28 200/80
5,00 m	10/26 200/60	12/26 200/60	12/28 200/60	12/30 200/80	12/32 200/80	12/34 200/80
6,00 m	12/28 200/60	12/32 200/80	12/34 200/80	12/36 200/80	12/38 290/80	12/40 290/80
7,00 m	12/34 200/80	12/36 290/80	12/40 290/80	12/42 290/80	12/44 290/80	
8,00 m	12/38 290/80	12/42 290/80	12/46 290/80	12/48 290/80		

Residential building, ceilings

(service classes 1-2, load-duration class: **medium-term**) Dead-load g_k (40%) e. g. self-weight and alternating load q_k (60%) e. g. wind, snow, live-load

Span L	Uniformly distributed load q_k					
	$q_k = 3,00 \text{ kN/m}$	$q_k = 4,00 \text{ kN/m}$	$q_k = 5,00 \text{ kN/m}$	$q_k = 6,00 \text{ kN/m}$	$q_k = 7,00 \text{ kN/m}$	$q_k = 8,00 \text{ kN/m}$
	Cross timber section w/l [cm/cm]	Cross timber section w/l [cm/cm]	Cross timber section w/l [cm/cm]	Cross timber section w/l [cm/cm]	Cross timber section w/l [cm/cm]	Cross timber section w/l [cm/cm]
	RICON® S	RICON® S	RICON® S	RICON® S	RICON® S	RICON® S
4,00 m	10/20 140/60	10/22 140/60	10/26 200/60	12/26 200/80	12/28 200/80	12/28 200/80
5,00 m	10/26 200/60	12/26 200/60	12/28 200/60	12/32 200/80	12/34 200/80	12/36 200/80
6,00 m	12/28 200/60	12/32 200/80	12/34 200/80	12/38 200/80	12/40 290/80	12/42 290/80
7,00 m	12/34 200/80	12/36 290/80	12/40 R290/80	12/44 290/80		
8,00 m	12/38 290/80	12/42 290/80	12/46 290/80	12/50 290/80		

Storage building, ceilings

(service classes 1-2, load-duration class: **long-term**) Dead-load g_k (40%) e. g. self-weight and alternating load q_k (60%) e. g. wind, snow, live-load

Span L	Uniformly distributed load q_k					
	$q_k = 3,00 \text{ kN/m}$	$q_k = 4,00 \text{ kN/m}$	$q_k = 5,00 \text{ kN/m}$	$q_k = 6,00 \text{ kN/m}$	$q_k = 7,00 \text{ kN/m}$	$q_k = 8,00 \text{ kN/m}$
	Cross timber section w/l [cm/cm]	Cross timber section w/l [cm/cm]	Cross timber section w/l [cm/cm]	Cross timber section w/l [cm/cm]	Cross timber section w/l [cm/cm]	Cross timber section w/l [cm/cm]
	RICON® S	RICON® S	RICON® S	RICON® S	RICON® S	RICON® S
4,00 m	10/22 140/60	10/24 140/60	10/26 200/60	12/26 200/80	12/28 200/80	12/30 200/80
5,00 m	10/26 200/60	12/28 200/60	12/30 200/60	12/34 200/80	12/36 290/80	12/38 290/80
6,00 m	12/28 200/60	12/32 200/80	12/36 200/80	12/40 290/80	12/42 290/80	
7,00 m	12/34 200/80	12/38 290/80	12/42 290/80	12/46 290/80		
8,00 m	12/38 290/80	12/44 290/80	12/48 290/80			

The table values are only to be applied for loading in direction of insertion. The minimum cross section of the secondary beam is calculated for timber C24 (S10). For the connection force of GIGANT, the live load over the bearing was set to 1,0 kN (man load upon the bearing).

Detailed information for static calculation are indicated in the ETA Static Folder. Find more information at www.knapp-verbinder.com/download

RICON® S screws

CS-screws RICON® S60 with cut point (RICON® S will supplied with the appropriate CS-screws)

- Art.-No. Z580 CS-screw 8x80 with patented half-peak
- Art.-No. Z581 CS-screw 8x160 with patented half-peak



Application: To screw in longitude (8x80) or end grain (8x160).

CS-screws RICON® S80 with cut point (RICON® S will supplied with the appropriate CS-screws)

- Art.-No. Z582 CS-screw 10x100 with patented half-peak
- Art.-No. Z583 CS-screw 10x200 with patented half-peak



Application: For screwing RICON® S into main (post) or secondary beam (latch).

RICON® S Accessories

Routing-jig RICON® S S60/S80

- Art.-No. K510 Routing-jig MULTI F60 (plywood) for all RICON® S60 sizes
 - Art.-No. K511 Routing-jig MULTI F80 (plywood) for all RICON® S60 sizes
- Advice:** The routing-jig MULTI F is suitable for a $\varnothing = 30$ mm guide bush (for plunge router) and a $\varnothing = 15$ mm TCT router cutter.

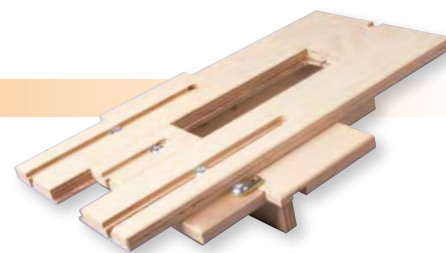

Application: For milling in concealed mounting.

TCT router cutter

- Art.-No. Zo68 TCT router cutter $\varnothing = 15$, Length = 40 mm and $\varnothing = 12$ mm Schaft



Application: To recess the rebate for RICON® S.

Pan head screws RICON® S80

- Art.-No. Z521 PH-screw 10x80
- Art.-No. Z522 PH-screw 10x120

Application: For screwing the interlayer on slanted screw connections.

Full threaded CS-screws with cut-point

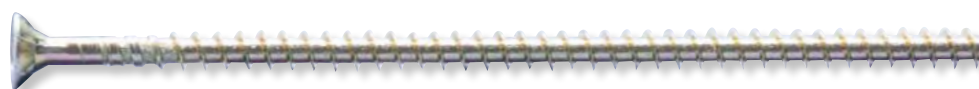
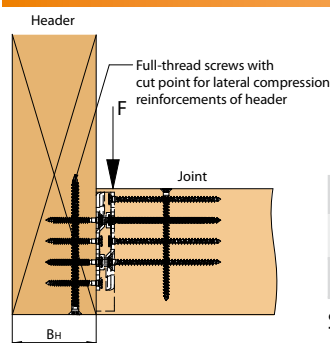

Diameter (d1)	Length (mm)													
$\varnothing = 8$ mm	160	180	200	220	240	260	280	300	350	400	450	500	550	600
$\varnothing = 10$ mm	160	180	200	220	240	260	280	300	350	400	450	500	550	600

Sizes available on request.

Application: Full threaded countersunk screws for lateral compression reinforcements of header and/or joint.

Clip lock RICON® S (made of stainless spring steel)

- Art.-No. K157 Clip lock RICON® S60
- Art.-No. K158 Clip lock RICON® S80

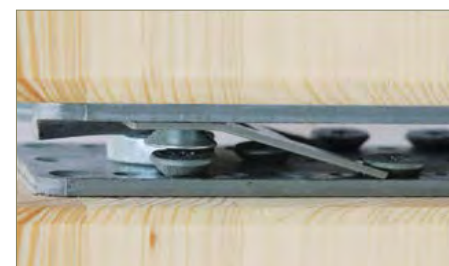
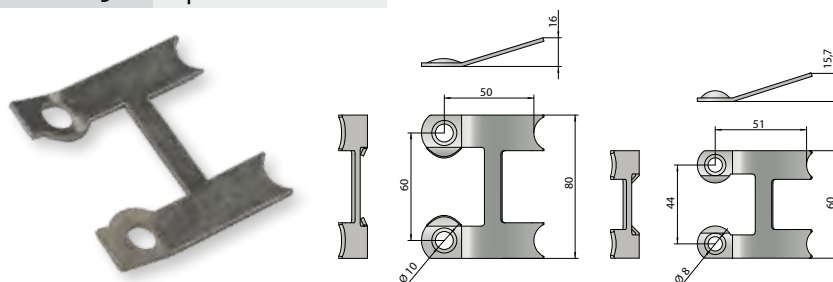

Application: The clip lock locks the connection against slide-in direction and is used for stress against slide-in direction or wind suction.

RICON® S collar bolt

Screwed collar bolt (VK) - Standard

Art.-No. Z595 S80: VK D16
Art.-No. Z594 S60: VK D12



1. Position collar bolt into the provided hole
2. Fasten collar bolt with full threaded CS-screw

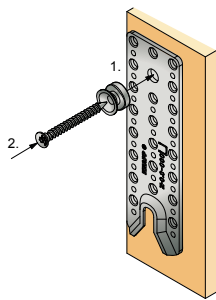

Necessary screws :
RICON® S60:
Header: 8x80
Joint: 8x160

RICON® S80:
Header: 10x100
Joint: 10x200

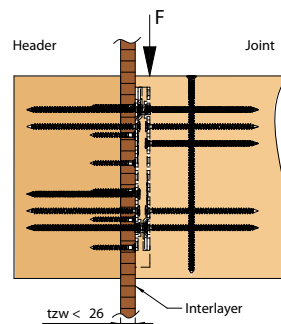
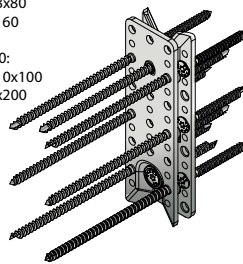

Application:

Screwed collar bolt for fast and direct screwing, especially on interlayers.

Hint: This way of connection requires very accurate rebate depth (no tolerances).

Retaining screw collar bolt (EK) - on request

Art.-No. Z558 S60: EK M12
Art.-No. Z559 S80: EK M16



1. Bore blind hole
2. Fasten socket head screw with coupling nut and jam nut to the connector
3. Adjust height and tighten up
4. Plug connectors in blind hole and fasten with RICON® S CS-screws

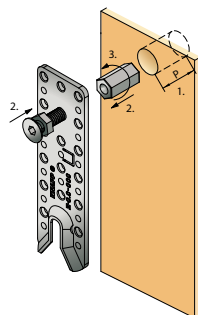

Blind hole for RICON® S60
Depth: t = 40 mm,
Diameter: D = 22 mm

Blind hole for RICON® S80
Depth: t = 50 mm,
Diameter: D = 28 mm

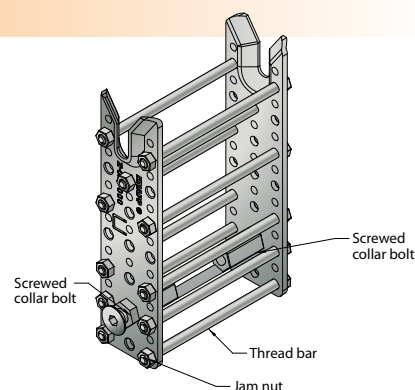
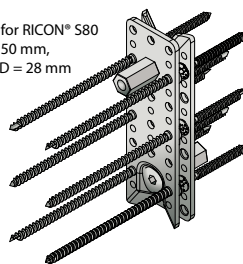

Application:

Retaining screw collar bolt for connections to concrete and/or wood components for timber engineering. Coupling nuts are used to connect pieces of threaded rod, anchor bolt or connecting bolts.

Spring retaining screw collar bolt (GK) - on request

Art.-No. Z592 S60: GK M12
Art.-No. Z593 S80: GK M16



1. Bore blind hole
2. Fasten socket head screw with flange nut and spring bolt housing on the connector
3. Plug connector in blind hole and fasten with RICON® S CS-screws

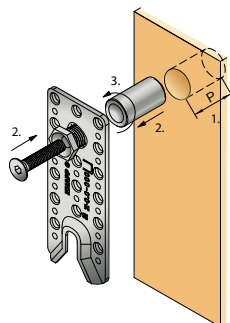

Blind hole for RICON® S60
Depth: t = 60 mm,
Diameter: D = 30 mm

Blind hole for RICON® S80
Depth: t = 70 mm,
Diameter: D = 35 mm

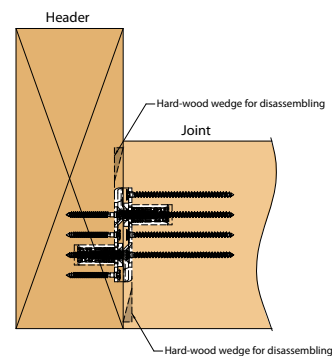
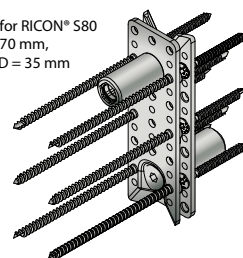

Application:

Spring retaining holding screw for the installation of components in-between two fixed parts (such as header latches or pillars).

RICON® S

Fire resistance

- Is an invisible connection required or particular requirements for fire protection, the system can be easily processed on three- or four sides covered.
- Jointless connection – no additional covers or fire protection ribbons required.
- According to DIN4102-2 20 mm wood covering are required for 30 minutes fire resistance. Even a higher fire resistance (for example R60) is possible.



RICON® S

Installation

- Routing machine with KNAPP® routing-jig.
- Installation with CNC joinery machine possible – all data for the standard CNC joinery machine programmes are included.



CNC joinery machine



1) Routing with routing-jig and routing machine.

Routing dimensions for RICON® S60 / S80				
Width	Length	Depth (VK, EK)	Depth (GK)	
60 mm / 80 mm	var.	25 mm	End grain	Longitudinal
			13 mm	13 mm

Installation RICON® S VS



2) Position the screws



3) Screw on



4) Screw on counter part

Installation RICON® S VK



2) Position the screws

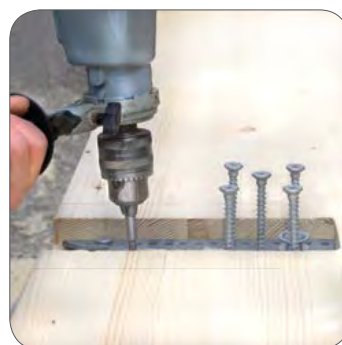

3) Screw on



4) Screw on counter part

Construction manuals, .DXF drawings for RICON® S-System as well as your personal consultant in your area, please visit: www.knapp-connectors.com/download

RICON®, RICON® S, GIGANT

Selected reference project



Object: renovation of a restaurant in Schnepfenried/France; SMA Syndicat mixte d'aménagement des stations de montagne de la vallée de Munster, F-68140 Munster; Architect: Ateliers d-Form, F-68230 Soultzbach Les Bains, www.atelier-d-form.com; Statics: Optime Ingénierie, 68230 Soultzbach Les Bains, contact@optime-be.com, Construction Company: Dattler, 20 rue des Prés, 68640 Feldbach, www.dattler.fr



Project: Indoor-Game Park „Wal“ in Friedrichskoog (D), www.wal-friedrichskoog.de; Connector: RICON® and GIGANT;
Architecture: rimpf Architektur www.rimpf.de; Timber companies: Gebr. Schütt KG GmbH & Co. www.schuetz-holzbau.de

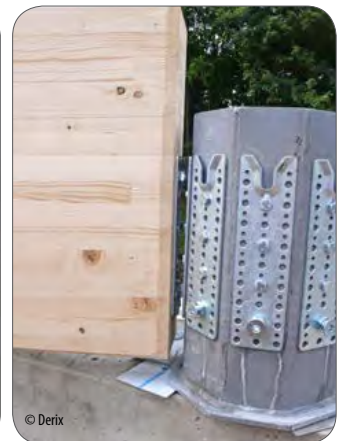

Project: Community Center Hünstetten-Oberlibbach; Eigenbetrieb für Entwicklungs- und Erschließungsgebiete Hünstetten; Construction 2010;
Architect: Planungsbüro Peichl Project, Fulda; Generalunternehmer: C + P Schlüsselfertiges Bauen GmbH & Co. KG, Angelburg; Planner: ing.-Büro Sturmius feuerstein, Petersberg; inspection engineer: Kind & Partner, Prof. Dr.-ing. Steffen Kind, Wiesbaden; Wood construction: Sängler Holzbau GmbH & Co. KG, Breidenbach; Planner: Holzbau W. u. J. Derix GmbH & co., Wilhelm Derix, Niederkrüchten

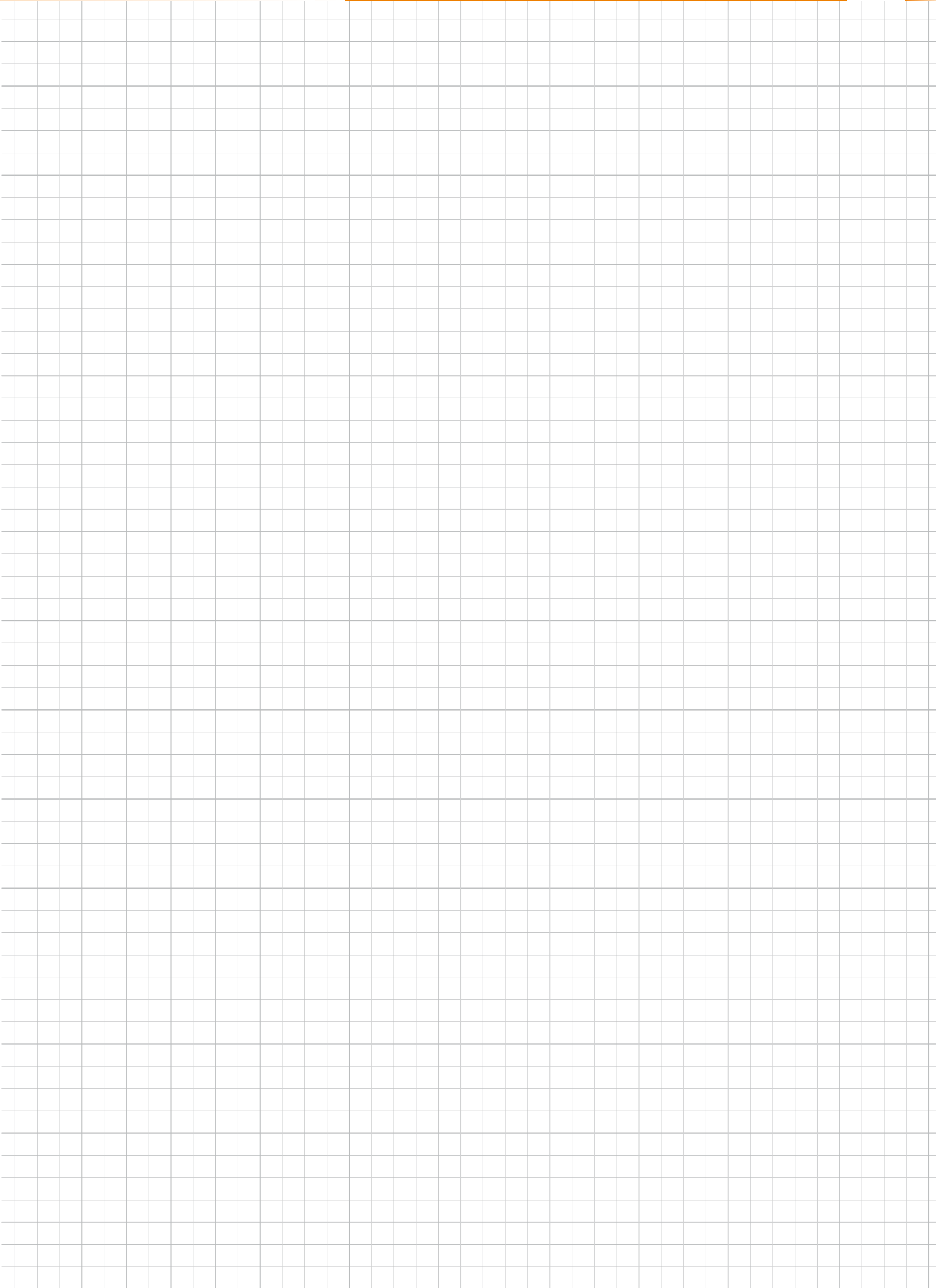



Contact

Tel.: +43 (0)7474 / 799 10
Tel.: +49 (0)8106 / 99 55 99 0
info@knapp-connectors.com

knapp-connectors.com/contact



Service

Do you have questions about an optimal solution for your project? Find your sales representative easily on our website:

knapp-connectors.com/ad



order 24h/24 online-store

You want to order around the clock? Our **KNAPP® online-store** is open 24h each day.*

knapp-connectors.com/online-store
* not available in Austria and Switzerland.



Download

All brochures, data sheets, technical details are downloadable from our web site.

knapp-connectors.com/download



Concealed | Self-tightening | Demountable



The technical contents in this brochure are valid, until a (on our website for download) new brochure is available. This brochure is the exclusive property of Knapp GmbH. Duplication, reproduction or publication, including excerpts, only with the prior written permission of Knapp GmbH. All calculations given in this brochure are made in subject to any printing and typing errors and other mistakes. Technical drawings and calculations, especially those affecting the statics, on customer's own responsibility. Any calculations and drawings in this respect by the company Knapp GmbH are subject to proposals for the orientation and / or liability for the accuracy and therefore not free the customer to wear it even for a proper drawing and calculation by a professional concern. Picture credits are available and can be requested if required. All rights reserved. Copyright © 2014 by Knapp GmbH.



Knapp GmbH | Wassergasse 31 | A-3324 Euratsfeld | Tel.: +43 (0)7474 / 799 10 | Fax: +43 (0)7474 / 799 10 99

Knapp GmbH Niederlassung Deutschland | Föhrenweg 1 | D-85591 Vaterstetten
Tel.: +49 (0)8106 / 99 55 99 0 | Fax: +49 (0)8106 / 99 55 99 20 | E-Mail: info@knapp-connectors.com

KNAPP®
connectors.com